



*The Association of
Pool & Spa Professionals™*

2012 INTERNATIONAL
**SWIMMING POOL
AND SPA
CODE**

2012 ISPS SC

PUBLIC VERSION 1.0, FEBRUARY 2011

**INTERNATIONAL SWIMMING POOL AND SPA CODE™
PUBLIC VERSION 1.0**

First Printing

Publication Date: February 2011

COPYRIGHT © 2011

INTERNATIONAL CODE COUNCIL, INC.

With the Cooperating Sponsorship of

The Association of Pool & Spa Professionals™

ALL RIGHTS RESERVED. This version of the *International Swimming Pool and Spa Code™* is a copyrighted work owned by the International Code Council, Inc. Without advance written permission from the copyright owner, no part of this work may be reproduced, distributed or transmitted in any form or by any means, including, without limitation, electronic, optical or mechanical means (by way of example, and not limitation, photocopying or recording by or in an information storage retrieval system). For information on permission to copy material exceeding fair use, please contact: Publications, 4051 West Flossmoor Road, Country Club Hills, IL 60478. Phone 1-888-ICC-SAFE (422-7233).

Trademarks: "International Code Council," the "International Code Council" logo and the "International Swimming Pool and Spa Code" are trademarks of the International Code Council, Inc.

PRINTED IN THE U.S.A.

PREFACE

Introduction

All levels of government and Building Safety Professionals recognize the need for a mandatory set of baseline requirements which comprehensively address all aspects of swimming pool and spa safety. To date, swimming pool and spa safety requirements have been addressed in the codes and standards but never in a single comprehensive package of requirements. The purpose of the *International Swimming Pool and Spa Code* is to coordinate and enhance in a single code the provisions previously found in the International Codes and Association of Pool & Spa Professionals (APSP) standards to meet the requirements of the Virginia Graeme Baker Act to upgrade pool and spa safety. This comprehensive code establishes minimum regulations using prescriptive and performance-related provisions.

The *International Swimming Pool and Spa Code* provides many benefits, among which is the model code development process that offers an international forum for pool and spa professionals to discuss the science and performance of such vessels. This forum provides an excellent arena to debate improvements to the ICC Family of Codes and Standards. The ICC system promotes the mission of the ICC and consistency in the application of codes worldwide.

APSP supports the adoption of the *International Swimming Pool and Spa Code*.

You can find more information at: <http://www.iccsafe.org/cs/ISPSC/Pages/default.aspx>

Development

Public Version 1.0 of the *International Swimming Pool and Spa Code* was prepared in 2011 by the Swimming Pool Code Drafting Committee (SPCDC) established by the ICC Board of Directors, with the Association of Pool & Spa Professionals as Cooperating Sponsors. The SPCDC is a broad based committee (see page v) representing a balance of interests consistent with the ICC Governmental Consensus process and revised OMB Circular A-119 which establishes policies on Federal use and development of voluntary consensus codes and standards. The SPCDC was composed of 15 individuals from public, private and nonprofit sectors with expertise in disciplines critical to the topics in the *International Swimming Pool and Spa Code*. The SPCDC was supported by several Work Groups composed of additional experts, along with a staff Secretariat and three staff experts from both ICC and APSP.

The intent was to develop a comprehensive set of regulations for swimming pools and spas consistent and coordinated with the I-Codes. In supporting this effort, APSP further notes: "While it is recognized that proper construction and installation are essential, safe use of pools and spas requires common sense, including constant adult supervision of children, and proper maintenance. It is assumed and intended that pool users will exercise appropriate personal judgment and responsibility (including constant adult supervision of children) and that operators will create and enforce rules and warning appropriate for their pool/spa".

Technical content was developed from an initial staff resource document, that utilized provisions from the International Codes and the applicable APSP standards. The APSP standards considered were:

- ANSI-1 2003 Public Swimming Pools
- ANSI-2 1999 Public Spas
- ANSI-3 1999 Permanent Residential Spas
- ANSI-4 2007 Aboveground/On-ground Residential Swimming Pools
- ANSI-5 2003 Residential In-ground Swimming Pools
- ANSI-6 1999 Portal Spas
- ANSI-7 2006 Suction Entrapment Avoidance
- ANSI-8 2005 Model Barrier Code
- ANSI-9 2005 Aquatic Recreational Facilities
- ANSI-11 2009 Standard for water quality in public swimming pools and spas

The SPCDC and its Work Groups comprehensively reviewed the requirements in the existing 2009 International Codes and the standards noted above in an effort to draft comprehensive language for pool and spa safety while at the same time making sure the language resulted in adoptable and enforceable I-Code language. Consistent with the development of other I-Codes, the *International Swimming Pool and Spa Code* Public Version 1.0 was developed with the intent to establish provisions consistent with the intent of the I-Codes to adequately protect public health, safety and welfare; provisions that do not unnecessarily increase construction costs; provisions that do not restrict the use of new materials, products or methods of construction; and provisions that do not give preferential treatment to particular types or classes of materials, products or methods of construction.

Public Meetings

In order to gain the views of pool and spa professionals and associated industries, and all other interested parties, three public SPCDC meetings were conducted (see the schedule on page viii). Changes to the text of the draft were accepted at the meetings of the full committee; changes to the text were also considered at the Work Group meetings prior to presentation to the full committee. An updated draft was posted on the ICC web site after every SPCDC meeting which served as the baseline for the next period of Work Group meetings followed by consideration by the full committee. In addition to the changes made at each SPCDC meeting, editorial changes have been made for consistency and correlation purposes.

Subsequent Versions

This is the first and only public version to be issued. Proposed revisions to Public Version 1.0 will be in the form of code changes that will be processed in accordance with ICC's Code Development Process comprised of Code Development and Final Action Hearings in 2011, resulting in the 2012 *International Swimming Pool and Spa Code*. See the schedule on page viii. A code change form is provided on page ix.

Adoption

The *International Swimming Pool and Spa Code* Public Version 1.0 is available as a resource document to guide adoption and use by jurisdictions internationally. Its use within a governmental jurisdiction is intended to be accomplished through adoption by reference in accordance with proceedings establishing the jurisdiction's laws. At the time of adoption, jurisdictions should insert the appropriate information in provisions requiring specific local information, such as the name of the adopting jurisdiction. These locations are shown in bracketed words in small capital letters in the code and in the sample adoption ordinance. The sample adoption ordinance on page vii addresses several key elements of a code adoption ordinance, including the information required for insertion into the code text.

Maintenance

The *International Swimming Pool and Spa Code* will be kept up to date through the review of proposed changes submitted by code enforcement officials, industry representatives, design professionals and other interested parties. Proposed changes will be carefully considered through an open code development process in which all interested and affected parties may participate.

For more information regarding the code development process, contact: ICC at 4051 West Flossmoor Road, Country Club Hills, Illinois 60478.

While the development procedure of the *International Swimming Pool and Spa Code* assures the highest degree of care, the ICC, APSP and their members and those participating in the development of this code do not accept any liability resulting from compliance or noncompliance with the provisions given herein, for any restrictions imposed on materials or processes, or for the completeness of the text. ICC and APSP do not have power or authority to police or enforce compliance with the contents of this code. Only the governmental body that enacts the code into law has such authority.

Letter Designations in Front of Section Numbers

In each code development cycle, proposed changes to the code are considered at the Code Development Hearings by the applicable ICC Code Development Committee, whose action constitutes a recommendation to the voting membership for final action on the proposed change. Proposed changes to a code section that has a section number beginning with a letter in brackets are considered by a different code development committee. For example, Chapter 1 includes a [A] in the title. Proposed changes submitted to sections in Chapter 1 will be considered by the ICC Administration Code Development Committee at the code development hearings.

The content of sections in this code that begin with a letter designation are maintained by another code development committee in accordance with the following:

[A]= Administration Code Development Committee

[E] = *International Energy Conservation Code* Development Committee

Developed by

Members of the Swimming Pool Code Drafting Committee

Chair: D. Kris Bridges, CBO, Combination Inspector II, City of Martinsville, VA

Vice Chair: Ron Lacher, PE, Rep: APSP, President, Pool Engineering Inc., Anaheim, CA

Maria Bella

Rep: APSP
Professional Pool Solutions, LLC
Reading, PA

Jim Bastian

Rep: APSP
Westport Pools
Maryland Heights, MO

Kyle Chaikin

Rep: APSP
Chaikin Pools, Inc.
Farmingdale, NY

Justin DeWitt, PE, LEED AP

Chief of General Engineering
Illinois Department of Public Health
Springfield, IL

James Dingman

Staff Engineering Associate
Underwriters Laboratories
Northbrook, IL

Helen DiPietro

Fire Safety Programs Administrator
North Carolina Department of Insurance/
Office of State Fire Marshal
Raleigh, NC

Jason K. Finley

Building Inspector II
City of Palm Desert, CA

Kenneth Gregory

President
Holland Commercial Pools
Altamonte Springs, FL

Dan Johnson, CBP

Rep: APSP
President
Swim, Incorporated
Sarasota, FL

Ed Kulik

Chief Building Official
Fire, Building and Life Safety, Good Year
Department
Goodyear, AZ

Steve Macey

Rep: APSP
Watkins Manufacturing
Vista, CA

Ringo McCollum, CBO, MCP

Building Official
White County Building Inspections
Cleveland, GA

Keith Zars

Rep: APSP
Keith Zars Pool Inc.
San Antonio, TX

Content Developed with the Research and Input of

Work Group Participants and Public Meeting Attendees, including

A Safe Child, Artistic Railings, Inc., Association of Pool and Spa Professionals, Balboa Water Group, Bowles Fluidics Corporation, Building Officials Association of Florida, City of Martinsville, CSA International, D&D Technologies, Dimension 1 Spas, Duraflex, Duravit USA Inc., Endless Pools Inc., Filbur Manufacturing, Homeland Vinyl Products, Illuminating Engineering Society, International Association of Lighting Designers, International Hot Tub Association, Intertek Group, Master Spas Inc., Musco Sports Lighting, National Ornamental & Miscellaneous Metals Association, North Carolina Department of Environment and Natural Resources, NSF International, ONELUXstudio, Plastic Pipe and Fittings Association, RC Quinn Consulting, Inc., Sundance Spas, Swimex Inc., Tolomato Community Development District, Town of Queen Creek, United States Centers for Disease Control and Prevention, USA Diving, Viking Pools, Water Quality Association, WaterWay Plastics, Watkins Manufacturing Corporation, World Waterpark Association

ICC/APSP Project Staff

Project Managers

*Tom Frost, AIA, ICC, Senior Vice President
Mike Pfeiffer, PE, ICC, Deputy Senior Vice President*

Staff Secretariats

*Carvin DiGiovanni, APSP, Senior Director, Technical and Standards
Fred Grable, PE, ICC, Staff Engineer, Plumbing
Shawn Martin, ICC Director of Industry Relations, PMG*

ORDINANCE

The International Codes are designed and promulgated to be adopted by reference by ordinance. Jurisdictions wishing to adopt the *International Swimming Pool and Spa Code™* as an enforceable regulation governing aquatic vessels should ensure that certain factual information is included in the adopting ordinance at the time adoption is being considered by the appropriate governmental body. The following sample adoption ordinance addresses several key elements of a code adoption ordinance, including the information required for insertion into the code text.

SAMPLE ORDINANCE FOR ADOPTION OF THE INTERNATIONAL SWIMMING POOL AND SPA CODE ORDINANCE NO. _____

An ordinance of the [JURISDICTION] adopting the *International Swimming Pool and Spa Code™*, regulating and governing aquatic vessels in the [JURISDICTION]; providing for the issuance of permits and collection of fees thereof; repealing Ordinance No. _____ of the [JURISDICTION] and all other ordinances and parts of the ordinances in conflict therewith.

The [GOVERNING BODY] of the [JURISDICTION] does ordain as follows:

Section 1. That a certain document, three (3) copies of which are on file in the office of the [TITLE OF JURISDICTION'S KEEPER OF RECORDS] of [NAME OF JURISDICTION], being marked and designated as the *International Swimming Pool and Spa Code*, including Appendix Chapters [FILL IN THE APPENDIX CHAPTERS BEING ADOPTED], as published by the International Code Council, be and is hereby adopted as the Swimming Pool and Spa Code of the [JURISDICTION], in the State of [STATE NAME] for regulating and governing aquatic vessels as herein provided; providing for the issuance of permits and collection of fees thereof; and each and all of the regulations, provisions, penalties, conditions and terms of said Swimming Pool and Spa Code on file in the office of the [JURISDICTION] are hereby referred to, adopted, and made a part hereof, as if fully set out in this ordinance, with the additions, insertions, deletions and changes, if any, prescribed in Section 2 of this ordinance.

Section 2. The following sections are hereby revised:

Section 101.1. Insert: [NAME OF JURISDICTION]

Section 105.6.2: Insert: [FEE SCHEDULE].

Section 105.6.3. Insert: [PERCENTAGES]

Section 3. That Ordinance No. _____ of [JURISDICTION] entitled [FILL IN HERE THE COMPLETE TITLE OF THE ORDINANCE OR ORDINANCES IN EFFECT AT THE PRESENT TIME SO THAT THEY WILL BE REPEALED BY DEFINITE MENTION] and all other ordinances or parts of ordinances in conflict herewith are hereby repealed.

Section 4. That if any section, subsection, sentence, clause or phrase of this ordinance is, for any reason, held to be unconstitutional, such decision shall not affect the validity of the remaining portions of this ordinance. The [GOVERNING BODY] hereby declares that it would have passed this ordinance, and each section, subsection, clause or phrase thereof, irrespective of the fact that any one or more sections, subsections, sentences, clauses and phrases be declared unconstitutional.

Section 5. That nothing in this ordinance or in the International Swimming Pool and Spa Code hereby adopted shall be construed to affect any suit or proceeding impending in any court, or any rights acquired, or liability incurred, or any cause or causes of action acquired or existing, under any act or ordinance hereby repealed as cited in Section 3 of this ordinance; nor shall any just or legal right or remedy of any character be lost, impaired or affected by this ordinance.

Section 6. That the [JURISDICTION'S KEEPER OF RECORDS] is hereby ordered and directed to cause this ordinance to be published. (An additional provision may be required to direct the number of times the ordinance is to be published and to specify that it is to be in a newspaper in general circulation. Posting may also be required.)

Section 7. That this ordinance and the rules, regulations, provisions, requirements, orders and matters established and adopted hereby shall take effect and be in full force and effect [TIME PERIOD] from and after the date of its final passage and adoption.

INTERNATIONAL SWIMMING POOL AND SPA CODE SCHEDULE

The Swimming Pool Code Drafting Committee (SPCDC) completed Public Version 1.0 of the International Swimming Pool and Spa Code. The schedule includes the following steps:

Distribute/post Resource Document	September 29, 2010
1 st Meeting	October 13 – 14, 2010; Chicago
2 nd Meeting	November 30 – December 1, 2010; Chicago
3 rd Meeting (Final meeting)	January 11 – 13, 2011; Orlando
Call for committee	To be posted by January 31, 2011
Public Version 1.0 posted for Code Change Submittals	February 1, 2011
Code Change Submittal Deadline	March 1, 2011
Proposed Changes to the ISPSC Posted	April 15, 2011
2011 ISPSC Code Development Hearing (with the IGCC hearing)	May 16, 2011
Report of Public Hearing Posted	To be posted June 27, 2011
Deadline for receipt of Public Comments	August 12, 2011
Public Comments Final Action Agenda Posted	To be posted September 16, 2011
2011 ISPSC Final Action Hearing (with the IGCC hearing)	November 2, 2011
Publish 2012 ISPSC	March 2012
Next cycle of ISPSC development	Part of Group B Codes to be considered in 2013 with Code Change Submittals due January 3, 2013

For a detailed schedule, please visit: <http://www.iccsafe.org/cs/ISPSC/Pages/DevSchedule.aspx>



**PUBLIC CODE CHANGE PROPOSAL FORM
FOR PUBLIC PROPOSALS TO PUBLIC VERSION 1.0 OF
THE INTERNATIONAL SWIMMING POOL AND SPA CODE**

CLOSING DATE: All Proposals Must Be Received by March 1, 2011.

The 2011 ISPSC Code Development Hearings are scheduled for May 16, 2011, Dallas, TX.

1)

Name:		Date:	
Jurisdiction/Company:			
Submitted on Behalf of:			
Address:			
City:		State:	Zip Code:
Phone:	Ext.:	Fax:	
E-mail address (see item 3 below):			

2) **Copyright Release:** In accordance with Council Policy #28 Code Development, all Code Change Proposals, Floor Modifications and Public Comments are required to include a copyright release. A copy of the copyright release form is included at the end of this form. Please follow the directions on the form. This form as well as an alternative release form can also be downloaded from the ICC website at www.iccsafe.org.

If you have previously executed the copyright release for this cycle, please check the box below:

2011 ISPSC Cycle copyright release on file.

3) **E-mail address:** Your email address will be published with your code change proposal unless you check here.

4) **Be sure to format your proposal and include all information as indicated below and in the Code Change Proposal Instructions' section on Page x of this form.**

5) Code change proposals should be sent to the following office via regular mail or email. An e-mail submittal is preferred, including an electronic version in Word. The only formatting needed is **BOLD**, ~~STRIKEOUT~~ AND UNDERLINING. Please do not provide additional formatting such as tabs, columns, etc., as this will be done by ICC. **ALSO REMOVE TRACK CHANGES, AUTOMATIC NUMBERING, OR ANY OTHER ADVANCED WORD FORMATTING TOOLS FROM YOUR CODE CHANGE PROPOSAL(S) prior to submittal as these formatting tools cause processing difficulties.**

Please use a separate form (see page xi) for each proposal submitted. Note: All code changes received will receive an acknowledgment by approximately March 8, 2011. Please contact the ICC staff listed below if you do not receive an acknowledgment by March 8, 2011.

Please check here if separate graphic file provided. Graphic materials (Graphs, maps, drawings, charts, photographs, etc.) must be submitted as separate electronic files in .CDR, .IA, .TIF or .JPG format (300 DPI Minimum resolution; 600 DPI or more preferred) even though they may also be embedded in your Word submittal.

Send to:

International Code Council
Chicago District Office
Attn: Dynice Broadnax
4051 West Flossmoor Road
Country Club Hills, IL 60478-5795
Fax: 708/799-0320
codechanges@iccsafe.org

CODE CHANGE PROPOSAL INSTRUCTIONS

Please provide all of the following items in your code change proposal (see form on page xi). Your proposal should be entered on page 3 as a separate file. However, please read the instructions provided below for each part of the code change proposal. The sections identified in parentheses are the applicable sections from CP #28 Code Development. The full procedures can be downloaded from www.iccsafe.org.

PROPOSAL FORMATTING:

Show the proposal using ~~strikeout~~, underline format. At the beginning of each section, one of the following instruction lines are also needed:

- Revise as follows
- Add new text as follows
- Delete and substitute as follows
- Delete without substitution

The only formatting that is needed is **BOLDING**, ~~STRIKEOUT~~ AND UNDERLINING. Please do not provide additional formatting such as tabs, columns etc. as this will be done by ICC. **DO NOT USE THE TRACKING CHANGES OPTION, AUTOMATIC NUMBERING, OR ANY OTHER ADVANCED FORMATTING TOOLS PROVIDED BY WORD.**

SUPPORTING INFORMATION: (3.3.4 & 3.4)

The following items are required to be included in your proposal:

1. The proponent shall clearly state the purpose of the proposed code change (e.g., clarify the Code; revise outdated material; substitute new or revised material for current provision of the Code; add new requirements to the Code; delete current requirements, etc.)
2. The proponent shall justify changing the current code provisions, stating why the proposal is superior to the current provisions of the Code. Proposals that add or delete requirements shall be supported by a logical explanation which clearly shows why the current Code provisions are inadequate or overly restrictive, specifies the shortcomings of the current Code provisions and explains how such proposals will improve the Code.
3. The proponent shall substantiate the proposed code change based on technical information and substantiation. Substantiation provided which is reviewed in accordance with Section 4.2 and determined as not germane to the technical issues addressed in the proposed code change shall be identified as such. The proponent shall be notified that the proposal is considered an incomplete proposal in accordance with Section 4.3, and the proposal shall be held until the deficiencies are corrected. The proponent shall have the right to appeal this action in accordance with the policy of the ICC Board. The burden of providing substantiating material lies with the proponent of the code change proposal. A minimum of two copies of all substantiating information shall be submitted.
4. The proponent shall submit a bibliography of any substantiating material submitted with the code change proposal. The bibliography shall be published with the code change and the proponent shall make the substantiating materials available for review at the appropriate ICC office and during the public hearing.

REFERENCED STANDARDS: (3.4 & 3.6)

List any new referenced standards that are proposed to be referenced in the code and provide a minimum of two copies. For ICC rules on referenced standards, see Section 3.6 of CP #28. Additional copies will be required for committee members. ICC staff will provide you with a mailing list for the appropriate committees.

COST IMPACT: (3.3.4.6)

The proponent shall indicate one of the following regarding the cost impact of the code change proposal:

1. The code change proposal will increase the cost of construction; or
 2. The code change proposal will not increase the cost of construction.
- This information will be included in the published code change proposal.

CODE CHANGE SUBMITTAL EXAMPLE

Code: SP _____ – 11 (to be filled in by ICC)
302.6.1

Commenter: John Q. Public, P.E., Acme Pools, representing himself

Revise as follows:

302.6.1 Manuals. An operating and maintenance manual ~~in accordance with industry accepted standards~~ shall be provided for each piece of equipment requiring maintenance.

Reason: There are no industry standards for manuals. Each pool is unique.

Cost Impact: The code change proposal will not increase the cost of construction.

Public Hearing: Committee: AS AM D
Assembly: ASF AMF DF

ISPSC
CODE CHANGE PROPOSAL FORM
(See instructions on page x)

Code: SP_____ – 11(*to be filled in by ICC*)

Code Sections/Tables/Figures Proposed for Revision (3.3.2); Note: *If the proposal is for a new section, indicate (new).*

Proponent: Name/Company/Representing (3.3.1): *(NOTE: DO NOT USE ACRONYMS FOR YOUR COMPANY OR ORGANIZATIONAL NAME)*

Email Address:

Revise as follows:

Reason:

Cost Impact:

Public Hearing:	Committee:	AS	AM	D
	Assembly:	ASF	AMF	DF



International Swimming Pool and Spa Code

COPYRIGHT RELEASE FOR
2011 PROPOSALS, MODIFICATIONS and PUBLIC COMMENTS SUBMITTED ON THE ISPSC
PRODUCED & PUBLISHED BY THE
INTERNATIONAL CODE COUNCIL

This form is required for all Proposals, Floor Modifications and Public Comments submitted to the International Code Council. Only one signed Copyright release form is required for the entire 2011 ISPSC Cycle and will be kept on file and can be used for all Proposal, Floor Modification and Public Comment submittals you submit to ICC unless you represent multiple entities. An executed form is required for each entity represented.

I hereby grant and assign to ICC all rights in copyright I may have in any authorship contributions I make to ICC in the 2011 ISPSC Cycle in connection with any proposal and public comment, in its original form submitted or revised form, including written and verbal modifications submitted in accordance with Section 5.5.2 of CP #28. I understand that I will have no rights in any ICC publications that use such contributions in the form submitted by me or another similar form and certify that such contributions are not protected by the copyright of any other person or entity.

Signature: _____

Please type or print full name: _____

Jurisdiction/Company: _____

Entity Represented: _____

Contact info: Phone: _____ Email: _____

Date signed: _____

PLEASE FAX OR MAIL THE SIGNED COPYRIGHT RELEASE TO:

Fax: ICC Codes & Standards Department – 708/799-0320

Mail: ICC Codes & Standards Development
Chicago District Office
4051 W. Flossmoor Road
Country Club Hills, IL 60478-5795

TABLE OF CONTENTS

CHAPTER 1: ADMINISTRATION	1
SECTION 101: GENERAL.....	1
SECTION 102: APPLICABILITY.....	1
SECTION 103: DEPARTMENT OF BUILDING SAFETY.....	3
SECTION 104: DUTIES AND POWERS OF THE CODE OFFICIAL.....	3
SECTION 105: PERMITS.....	5
SECTION 106: INSPECTIONS.....	7
SECTION 107: VIOLATIONS.....	9
SECTION 108: MEANS OF APPEAL.....	10
CHAPTER 2: DEFINITIONS	13
SECTION 201: GENERAL.....	13
SECTION 202: DEFINITIONS.....	13
CHAPTER 3: GENERAL COMPLIANCE	23
SECTION 301: GENERAL.....	23
SECTION 302: ELECTRICAL, PLUMBING, MECHANICAL AND FUEL GAS REQUIREMENTS.....	23
SECTION 303: ENERGY.....	24
SECTION 304: FLOOD HAZARD AREAS.....	24
SECTION 305: BARRIER REQUIREMENTS.....	25
SECTION 306: DECKS.....	28
SECTION 307: GENERAL DESIGN.....	29
SECTION 308: DIMENSIONAL DESIGN.....	30
SECTION 309: EQUIPMENT.....	30
SECTION 310: SUCTION ENTRAPMENT AVOIDANCE.....	31
SECTION 311: CIRCULATION SYSTEMS.....	31
SECTION 312: FILTERS.....	32
SECTION 313: PUMPS AND MOTORS.....	33
SECTION 314: RETURN AND SUCTION FITTINGS.....	33
SECTION 315: SKIMMERS.....	34
SECTION 316: HEATERS.....	35
SECTION 317: AIR BLOWER AND AIR INDUCTION SYSTEM.....	36
SECTION 318: WATER SUPPLY.....	36
SECTION 319: SANITIZING EQUIPMENT.....	36
SECTION 320: WASTE WATER DISPOSAL.....	36
SECTION 321: LIGHTING.....	37
SECTION 322: LADDERS AND RECESSED TREADS.....	37

SECTION 323: SAFETY.....	39
CHAPTER 4: PUBLIC SWIMMING POOLS.....	41
SECTION 401: GENERAL.....	41
SECTION 402: DIVING	41
SECTION 403: BATHER LOAD	41
SECTION 404: REST LEDGES.....	43
SECTION 405: WADING POOLS	44
SECTION 406: DECKS AND DECK EQUIPMENT	44
SECTION 407: CIRCULATION SYSTEMS	46
SECTION 408: FILTERS.....	46
SECTION 409: SPECIFIC SAFETY FEATURES.....	46
SECTION 410: DRESSING AND SANITARY FACILITIES.....	47
SECTION 411: SPECIAL FEATURES	47
SECTION 412: SIGNAGE	49
CHAPTER 5: PUBLIC SPAS AND PUBLIC EXERCISE SPAS	51
SECTION 501: GENERAL.....	51
SECTION 502: MATERIALS	51
SECTION 503: STRUCTURE AND DESIGN	51
SECTION 504: PUMPS AND MOTORS	51
SECTION 505: RETURN AND SUCTION FITTINGS	52
SECTION 506: HEATER AND TEMPERATURE REQUIREMENTS.....	52
SECTION 507: WATER SUPPLY	52
SECTION 508: SANITIZING, OXIDATION EQUIPMENT AND CHEMICAL FEEDERS.....	52
SECTION 509: SAFETY FEATURES	53
CHAPTER 6: AQUATIC RECREATION FACILITIES	55
SECTION 601: GENERAL.....	55
SECTION 602: FLOORS	55
SECTION 603: MARKINGS AND INDICATORS.....	55
SECTION 604: CIRCULATION SYSTEMS	55
SECTION 605: HANDHOLDS AND ROPES.....	56
SECTION 606: DEPTHS	57
SECTION 607: BARRIERS	57
SECTION 608: NUMBER OF OCCUPANTS	57
SECTION 609: TOILET ROOMS AND BATHROOMS	57
SECTION 610: SPECIAL FEATURES	58
SECTION 611: SIGNAGE	60
CHAPTER 7: ONGROUND STORABLE RESIDENTIAL SWIMMING POOLS.....	63
SECTION 701: GENERAL.....	63

SECTION 702: LADDERS AND STAIRS	63
SECTION 703: DECKS	68
SECTION 704: CIRCULATION SYSTEM	70
CHAPTER 8: PERMANENT INGROUND RESIDENTIAL SWIMMING POOLS	71
SECTION 801: GENERAL.....	71
SECTION 802: DESIGN	71
SECTION 803: CONSTRUCTION TOLERANCES	71
SECTION 804: DIVING WATER ENVELOPES	71
SECTION 805: WALLS.....	73
SECTION 806: OFFSET LEDGES.....	73
SECTION 807: POOL FLOORS.....	73
SECTION 808: DIVING EQUIPMENT.....	74
SECTION 809: SPECIAL FEATURES	75
SECTION 810: CIRCULATION SYSTEMS	76
CHAPTER 9: PERMANENT RESIDENTIAL SPAS AND PERMANENT RESIDENTIAL EXERCISE SPAS	77
SECTION 901: GENERAL.....	77
SECTION 902: SAFETY FEATURES	77
CHAPTER 10: PORTABLE RESIDENTIAL SPAS AND PORTABLE RESIDENTIAL EXERCISE SPAS	79
SECTION 1001: GENERAL.....	79
CHAPTER 11: REFERENCED STANDARDS	81

[A] CHAPTER 1

ADMINISTRATION

PART 1 --- SCOPE AND APPLICATION

SECTION 101 GENERAL

101.1 Title. These regulations shall be known as the International Swimming Pool and Spa Code of [NAME OF JURISDICTION], hereinafter referred to as “this code.”

101.2 Scope. The provisions of this code shall apply to the construction, alteration, movement, renovation, replacement, repair and maintenance of aquatic vessels.

101.3 Intent. The purpose of this code is to provide minimum standards to safeguard life or limb, health, property and public welfare by regulating and controlling the design, construction, installation, quality of materials, location and maintenance or use of aquatic vessels.

101.4 Severability. If any section, subsection, sentence, clause or phrase of this code is for any reason held to be unconstitutional, such decision shall not affect the validity of the remaining portions of this code.

SECTION 102 APPLICABILITY

102.1 General. Where there is a conflict between a general requirement and a specific requirement, the specific requirement shall govern. Where, in any specific case, different sections of this code specify different materials, methods of construction or other requirements, the most restrictive shall govern.

102.2 Existing installations. Any aquatic vessel and related mechanical, electrical and plumbing systems lawfully in existence at the time of the adoption of this code shall be permitted to have their use and maintenance continued if the use, maintenance or repair is in accordance with the original design and no hazard to life, health or property is created.

102.3 Maintenance. All aquatic vessel and related mechanical, electrical and plumbing systems, both existing and new, and all parts thereof, shall be maintained in proper operating condition in accordance with the original design in a safe and sanitary condition. All devices or safeguards required by this code shall be maintained in compliance with the code edition under which they were installed.

The owner or the owner’s designated agent shall be responsible for maintenance of all systems. To determine compliance with this provision, the code official shall have the authority to require any system to be reinspected.

102.4 Additions, alterations or repairs. Additions, alterations, renovations or repairs to any aquatic vessel and related systems shall conform to that required for a new system without requiring the existing systems to comply with all the requirements of this code. Additions, alterations or repairs shall not cause existing systems to become unsafe, insanitary or overloaded.

Minor additions, alterations, renovations and repairs to existing systems shall be permitted in the same manner and arrangement as in the existing system, provided that such repairs or replacement are not hazardous and are approved.

102.5 Historic buildings. The provisions of this code relating to the construction, alteration, repair, enlargement, restoration, relocation or moving of aquatic vessels or systems shall not be mandatory for

existing aquatic vessels or systems identified and classified by the state or local jurisdiction as part of a historic structure when such aquatic vessels or systems are judged by the code official to be safe and in the public interest of health, safety and welfare regarding any proposed construction, alteration, repair, enlargement, restoration, relocation or moving of such aquatic vessel.

102.6 Moved aquatic vessels. Except as determined by Section 102.2, systems that are a part of aquatic vessels or systems moved into or within the jurisdiction shall comply with the provisions of this code for new installations.

102.7 Referenced codes and standards. The codes and standards referenced in this code shall be those that are listed in Chapter 11 and such codes and standards shall be considered as part of the requirements of this code to the prescribed extent of each such reference. Where differences occur between provisions of this code and the referenced standards, the provisions of this code shall be the minimum requirements.

102.7.1 Application of the International Codes: Where the *International Residential Code* is referenced in this code, the provisions of the *International Residential Code* shall apply to related systems in detached one and two family dwellings and townhouses not more than three stories in height. All other related systems shall comply with the applicable International Code or referenced standard.

102.8 Requirements not covered by code. Any requirements necessary for the strength, stability or proper operation of an existing or proposed system, or for the public safety, health and general welfare, not specifically covered by this code shall be determined by the code official.

102.9 Other laws. The provisions of this code shall not be deemed to nullify any provisions of local, state or federal law.

102.10 Application of references. References to chapter or section numbers, or to provisions not specifically identified by number, shall be construed to refer to such chapter, section or provision of this code.

PART 2 --- ADMINISTRATION AND ENFORCEMENT

SECTION 103 DEPARTMENT OF BUILDING SAFETY

103.1 Creation of enforcement agency. The Department of Building Safety is hereby created and the official in charge thereof shall be known as the code official.

103.2 Appointment. The code official shall be appointed by the chief appointing authority of the jurisdiction.

103.3 Deputies. In accordance with the prescribed procedures of this jurisdiction and with the concurrence of the appointing authority, the code official shall have the authority to appoint a deputy code official, the related technical officers, inspectors, plan examiners and other employees. Such employees shall have powers as delegated by the code official.

103.4 Liability. The code official, member of the board of appeals or employee charged with the enforcement of this code, while acting for the jurisdiction in good faith and without malice in the discharge of the duties required by this code or other pertinent law or ordinance, shall not thereby be rendered liable personally and is hereby relieved from personal liability for any damage accruing to persons or property as a result of any act or by reason of an act or omission in the discharge of official duties. Any suit instituted against an officer or employee because of an act performed by that officer or employee in the lawful discharge of duties and under the provisions of this code shall be defended by legal representative of the jurisdiction until the final termination of the proceedings. The code official or any subordinate shall not be liable for cost in any action, suit or proceeding that is instituted in pursuance of the provisions of this code.

SECTION 104 DUTIES AND POWERS OF THE CODE OFFICIAL

104.1 General. The code official is hereby authorized and directed to enforce the provisions of this code. The code official shall have the authority to render interpretations of this code and to adopt policies and procedures in order to clarify the application of its provisions. Such interpretations, policies and procedures shall be in compliance with the intent and purpose of this code. Such policies and procedures shall not have the effect of waiving requirements specifically provided for in this code.

104.2 Applications and permits. The code official shall receive applications, review construction documents and issue permits for the erection, alteration, demolition and moving of aquatic vessels, related mechanical, electrical, plumbing systems, to inspect the premises for which such permits have been issued and enforce compliance with the provisions of this code.

104.3 Notices and orders. The code official shall issue all necessary notices or orders to ensure compliance with this code.

104.4 Inspections. The code official shall make all of the required inspections, or the code official shall have the authority to accept reports of inspection by approved agencies or individuals. Reports of such inspections shall be in writing and be certified by a responsible officer of such approved agency or by the responsible individual. The code official is authorized to engage such expert opinion as deemed necessary to report upon unusual technical issues that arise, subject to the approval of the appointing authority.

104.5 Identification. The code official shall carry proper identification when inspecting structures or premises in the performance of duties under this code.

104.6 Right of entry. Where it is necessary to make an inspection to enforce the provisions of this code, or where the code official has reasonable cause to believe that there exists in a structure or upon a premises a condition which is contrary to or in violation of this code which makes the structure or premises unsafe, dangerous or hazardous, the code official is authorized to enter the structure or premises at reasonable times to inspect or to perform the duties imposed by this code, provided that if such structure or premises be occupied that credentials be presented to the occupant and entry requested. If such structure or premises is unoccupied, the code official shall first make a reasonable effort to locate the owner or other person having charge or control of the structure or premises and request entry. If entry is refused, the code official shall have recourse to the remedies provided by law to secure entry.

104.7 Department records. The code official shall keep official records of applications received, permits and certificates issued, fees collected, reports of inspections, and notices and orders issued. Such records shall be retained in the official records for the period required for retention of public records.

104.8 Modifications. Wherever there are practical difficulties involved in carrying out the provisions of this code, the code official shall have the authority to grant modifications for individual cases, upon application of the owner or owner's representative, provided the code official shall first find that special individual reason makes the strict letter of this code impractical and the modification is in compliance with the intent and purpose of this code and that such modification does not lessen sustainability, health, accessibility, life safety and structural requirements. The details of action granting modifications shall be recorded and entered in the files of the department of building safety.

104.9 Alternative materials, methods and equipment. The provisions of this code are not intended to prevent the installation of any material or to prohibit any method of construction not specifically prescribed by this code, provided that any such alternative has been approved. An alternative material or method of construction shall be approved where the code official finds that the proposed design is satisfactory and complies with the intent of the provisions of this code, and that the material, method or work offered is, for the purpose intended, at least the equivalent of that prescribed in this code in quality, strength, effectiveness, durability and safety.

104.10 Required testing. Whenever there is insufficient evidence of compliance with the provisions of this code, or evidence that a material or method does not conform to the requirements of this code, or in order to substantiate claims for alternate materials or methods, the code official shall have the authority to require tests as evidence of compliance to be made at no expense to the jurisdiction.

104.10.1 Test methods. Test methods shall be as specified in this code or by other recognized test standards. In the absence of recognized and accepted test methods, the code official shall approve the testing procedures.

104.10.2 Testing agency. All tests shall be performed by an approved agency.

104.10.3 Test reports. Reports of tests shall be retained by the code official for the period required for retention of public records.

104.11 Alternative engineered design. The design, documentation, inspection, testing and approval of an alternative engineered design shall comply with Sections 104.11.1 through 104.11.6.

104.11.1 Design criteria. An alternative engineered design shall conform to the intent of the provisions of this code and shall provide an equivalent level of quality, strength, effectiveness, durability and safety. Material, equipment or components shall be designed and installed in accordance with the manufacturer's installation instructions.

104.11.2 Submittal. The registered design professional shall indicate on the permit application that the system is an alternative engineered design. The permit and permanent permit records shall indicate that an alternative engineered design was part of the approved installation.

104.11.3 Technical data. The registered design professional shall submit sufficient technical data to substantiate the proposed alternative engineered design and to prove that the performance meets the intent of this code.

104.11.4 Construction documents. The registered design professional shall submit to the code official two complete sets of signed and sealed construction documents for the alternative engineered design.

104.11.5 Design approval. Where the code official determines that the alternative engineered design conforms to the intent of this code, the system shall be approved. If the alternative engineered design is not approved, the code official shall notify the registered design professional in writing, stating the reasons thereof.

104.11.6 Inspection and testing. The alternative engineered design shall be tested and inspected in accordance with the requirements of Section 106.12.

104.12 Material and equipment reuse. Materials, equipment and devices shall not be reused unless such elements have been reconditioned, tested, placed in good and proper working condition and approved.

SECTION 105 PERMITS

105.1 When required. Any owner, or authorized agent who desires to construct, enlarge, alter, repair, move, or demolish an aquatic vessel or to erect, install, enlarge, alter, repair, remove, convert or replace any system, the installation of which is regulated by this code, or to cause any such work to be done, shall first make application to the code official and obtain the required permit for the work.

105.2 Application for permit. Each application for a permit, with the required fee, shall be filed with the code official on a form furnished for that purpose and shall contain a general description of the proposed work and its location. The application shall be signed by the owner or an authorized agent. The permit application shall contain such other information required by the code official.

105.3 Construction documents. Construction documents, engineering calculations, diagrams and other such data shall be submitted in two or more sets with each application for a permit. The code official shall require construction documents, computations and specifications to be prepared and designed by a registered design professional when required by state law. Construction documents shall be drawn to scale and shall be of sufficient clarity to indicate the location, nature and extent of the work proposed and show in detail that the work conforms to the provisions of this code.

105.4 Time limitation of application. An application for a permit for any proposed work shall be deemed to have been abandoned 180 days after the date of filing unless such application has been pursued in good faith or a permit has been issued; except that the code official is authorized to grant one or more extensions of time for additional periods not exceeding 180 days each. The extension shall be requested in writing and justifiable cause demonstrated.

105.5 Permit issuance. The application, construction documents and other data filed by an applicant for permit shall be reviewed by the code official. If the code official finds that the proposed work conforms to the requirements of this code and all laws and ordinances applicable thereto, and that the fees specified in Section 105.6 have been paid, a permit shall be issued to the applicant.

105.5.1 Approved construction documents. When the code official issues the permit where construction documents are required, the construction documents shall be endorsed in writing and stamped "APPROVED." Such approved construction documents shall not be changed, modified or altered without authorization from the code official. All work shall be done in accordance with the approved construction documents.

The code official shall have the authority to issue a permit for the construction of a part of a system before the entire construction documents for the whole system have been submitted or approved, provided adequate information and detailed statements have been filed complying with all pertinent requirements of this code. The holders of such permit shall proceed at their own risk without assurance that the permit for the entire system will be granted.

105.5.2 Validity. The issuance of a permit or approval of construction documents shall not be construed to be a permit for, or an approval of, any violation of any of the provisions of this code or any other ordinance of the jurisdiction. No permit presuming to give authority to violate or cancel the provisions of this code shall be valid.

The issuance of a permit based upon construction documents and other data shall not prevent the code official from thereafter requiring the correction of errors in said construction documents and other data or from preventing building operations being carried on there under when in violation of this code or of other ordinances of this jurisdiction.

105.5.3 Expiration. Every permit issued shall become invalid unless the work authorized by such permit is commenced within 180 days after its issuance, or if the work authorized by such permit is suspended or abandoned for a period of 180 days after the time the work is commenced. The code official is authorized to grant, in writing, one or more extensions of time, for a period not more than 180 days. The extension shall be requested in writing and justifiable cause demonstrated.

105.5.4 Extensions. Any permittee holding an unexpired permit shall have the right to apply for an extension of the time within which the permittee will commence work under that permit when work is unable to be commenced within the time required by this section for good and satisfactory reasons. The code official shall extend the time for action by the permittee for a period not exceeding 180 days if there is reasonable cause. The fee for an extension shall be one-half the amount required for a new permit for such work.

105.5.5 Suspension or revocation of permit. The code official shall revoke a permit or approval issued under the provisions of this code in case of any false statement or misrepresentation of fact in the application or on the construction documents upon which the permit or approval was based.

105.5.6 Retention of construction documents. One set of approved construction documents shall be retained by the code official for a period of not less than 180 days from date of completion of the permitted work, or as required by state or local laws. One set of approved construction documents shall be returned to the applicant, and said set shall be kept on the site of the building or work at all times during which the work authorized thereby is in progress.

105.6 Fees. A permit shall not be issued until the fees prescribed in Section 105.6.2 have been paid, and an amendment to a permit shall not be released until the additional fee, if any, due to an increase of the systems, has been paid.

105.6.1 Work commencing before permit issuance. Any person who commences any work on a system before obtaining the necessary permits shall be subject to a fee as indicated in the adopted Fee schedule and would be in addition to the required permit fees.

105.6.2 Fee schedule. The fees for all work shall be as indicated in the following schedule:

[JURISDICTION TO INSERT APPROPRIATE SCHEDULE]

105.6.3 Fee refunds. The code official shall authorize the refunding of fees as follows:

1. The full amount of any fee paid hereunder that was erroneously paid or collected.
2. Not more than [SPECIFY PERCENTAGE] percent of the permit fee paid when no work has been done under a permit issued in accordance with this code.
3. Not more than [SPECIFY PERCENTAGE] percent of the plan review fee paid when an application for a permit for which a plan review fee has been paid is withdrawn or canceled before any plan review effort has been expended.

The code official shall not authorize the refunding of any fee paid except upon written application filed by the original permittee not later than 180 days after the date of fee payment.

SECTION 106 INSPECTIONS

106.1 General. Construction or work for which a permit is required shall be subject to inspection by the code official and such construction or work shall remain accessible and exposed for inspection purposes until approved. Approval as a result of an inspection shall not be construed to be an approval of a violation of the provisions of this code or of other ordinances of the jurisdiction. Inspections presuming to give authority to violate or cancel the provisions of this code or of other ordinances of the jurisdiction shall not be valid. It shall be the duty of the permit applicant to cause the work to remain accessible and exposed for inspection purposes. Neither the code official nor the jurisdiction shall be liable for expense entailed in the removal or replacement of any material required to allow inspection.

106.2 Preliminary inspection. Before issuing a permit, the code official is authorized to examine or cause to be examined buildings, structures and sites for which an application has been filed.

106.3 Required inspections and testing. All aquatic vessel installations or alterations thereto, including equipment, piping, and appliances related thereto, shall be inspected by the code official to ensure compliance with all the requirements of this code.

106.4 Other Inspections. In addition to the inspections specified above, the code official is authorized to make or require other inspections of any construction work to ascertain compliance with the provisions of this code and other laws that are enforced.

106.5 Inspection request. It shall be the duty of the holder of the permit or their duly authorized agent to notify the code official when work is ready for inspection. It shall be the duty of the permit holder to provide access to and means for inspections of such work that are required by this code.

106.6 Approval Required. Work shall not be done beyond the point indicated in each successive inspection without first obtaining the approval of the code official. The code official, upon notification, shall make the requested inspection and shall either indicate the portion of the construction that is satisfactory as completed, or notify the permit holder or his other agent wherein the same fails to comply with this code. Any portions that do not comply shall be corrected and such portion shall not be covered or concealed until authorized by the code official.

106.7 Approved agencies. Test reports submitted to the code official for consideration shall be developed by approved agencies that have satisfied the requirements as to qualifications and reliability.

106.8 Evaluation and follow-up inspection services. Prior to the approval of a closed, prefabricated system and the issuance of a permit, the code official shall require the submittal of an evaluation report on each prefabricated system indicating the complete details of the system, including a description of the system

and its components, the basis upon which the system is being evaluated, test results and similar information, and other data as necessary for the code official to determine conformance to this code.

106.9 Evaluation service. The code official shall designate the evaluation service of an approved agency as the evaluation agency, and review such agency's evaluation report for adequacy and conformance to this code.

106.10 Follow-up inspection. Except where ready access is provided to all systems, service equipment and accessories for complete inspection at the site without disassembly or dismantling, the code official shall conduct the frequency of in-plant inspections necessary to ensure conformance to the approved evaluation report or shall designate an independent, approved inspection agency to conduct such inspections. The inspection agency shall furnish the code official with the follow-up inspection manual and a report of inspections upon request, and the system shall have an identifying label permanently affixed to the system indicating that factory inspections have been performed.

106.11 Test and inspection records. All required test and inspection records shall be available to the code official at all times during the fabrication of the system and the installation of the system, or such records as the code official designates shall be filed.

106.12 Special inspections. Special inspections of alternative engineered design systems shall be conducted in accordance with Section 104.11.6.

106.13 Periodic inspection. The registered design professional or designated inspector shall periodically inspect and observe the alternative engineered design to determine that the installation is in accordance with the approved construction documents. All discrepancies shall be brought to the immediate attention of the contractor for correction. Records shall be kept of all inspections.

106.14 Written report. The registered design professional shall submit a final report in writing to the code official upon completion of the installation, certifying that the alternative engineered design conforms to the approved construction documents. A notice of approval for the system shall not be issued until a written certification has been submitted.

106.15 Testing. Systems shall be tested as required by this code. Tests shall be made by the permit holder and the code official shall have the authority to witness such tests.

106.16 New, altered, extended or repaired systems. New systems and parts of existing systems that have been altered, extended or repaired shall be tested as prescribed by this code.

106.17 Equipment, material and labor for tests. All equipment, material and labor required for testing a system or part thereof shall be furnished by the permit holder.

106.18 Reinspection and testing. Where any work or installation does not pass any initial test or inspection, the necessary corrections shall be made to comply with this code. The work or installation shall then be resubmitted to the code official for inspection and testing.

106.19 Approval. After the prescribed tests and inspections indicate that the work complies in all respects with this code, a notice of approval shall be issued by the code official.

106.19.1 Revocation. The code official is authorized to, in writing, suspend or revoke a notice of approval issued under the provisions of this code wherever the notice is issued in error, or on the basis of the incorrect information supplied, or where it is determined that the building or structure, premise, system or portion thereof is in violation of any ordinance or regulation or any of the provisions of this code.

106.20 Temporary connection. The code official shall have the authority to authorize the temporary connection of the building or system to the utility source for the purpose of testing systems.

106.21 Connection of service utilities. A person shall not make connections from a utility, source of energy, fuel, power, water system or sewer system to any building or system that is regulated by this code for which a permit is required until authorized by the code official.

SECTION 107 VIOLATIONS

107.1 Unlawful acts. It shall be unlawful for any person, firm or corporation to erect, construct, alter, repair, remove, demolish or utilize any system, or cause same to be done, in conflict with or in violation of any of the provisions of this code.

107.2 Notice of violation. The code official shall serve a notice of violation or order to the person responsible for the erection, installation, alteration, extension, repair, removal or demolition of work in violation of the provisions of this code, or in violation of a detail statement or the approved construction documents there under, or in violation of a permit or certificate issued under the provisions of this code. Such order shall direct the discontinuance of the illegal action or condition and the abatement of the violation.

107.3 Prosecution of violation. If the notice of violation is not complied with promptly, the code official shall request the legal counsel of the jurisdiction to institute the appropriate proceeding at law or in equity to restrain, correct or abate such violation, or to require the removal or termination of the unlawful aquatic vessel in violation of the provisions of this code or of the order or direction made pursuant thereto.

107.4 Violation penalties. Any person who shall violate a provision of this code or shall fail to comply with any of the requirements thereof or who shall erect, install, alter or repair an aquatic vessel in violation of the approved construction documents or directive of the code official, or of a permit or certificate issued under the provisions of this code, shall be guilty of a [SPECIFY OFFENSE], punishable by a fine of not more than [AMOUNT] dollars or by imprisonment not exceeding [NUMBER OF DAYS], or both such fine and imprisonment. Each day that a violation continues after due notice has been served shall be deemed a separate offense.

107.5 Stop work orders. Upon notice from the code official, work on any system that is being done contrary to the provisions of this code or in a dangerous or unsafe manner shall immediately cease. Such notice shall be in writing and shall be given to the owner of the property, or to the owner's agent, or to the person doing the work. The notice shall state the conditions under which work is authorized to resume. Where an emergency exists, the code official shall not be required to give a written notice prior to stopping the work. Any person who shall continue any work in or about the structure after having been served with a stop work order, except such work as that person is directed to perform to remove a violation or unsafe condition, shall be liable to a fine of not less than [AMOUNT] dollars or more than [AMOUNT] dollars.

107.6 Abatement of violation. The imposition of the penalties herein prescribed shall not preclude the legal officer of the jurisdiction from instituting appropriate action to prevent violation, or to prevent illegal use of an aquatic vessel, or to stop an illegal act, conduct, business or utilization of the plumbing on or about any premises.

107.7 Unsafe systems. Any system regulated by this code that is unsafe or that constitutes a fire or health hazard, insanitary condition, or is otherwise dangerous to human life is hereby declared unsafe. Any use of a system regulated by this code constituting a hazard to safety, health or public welfare by reason of inadequate maintenance, dilapidation, obsolescence, fire hazard, disaster, damage or abandonment is hereby declared an unsafe use. Any such unsafe system is hereby declared to be a public nuisance and shall be abated by repair, rehabilitation, demolition or removal.

107.7.1 Authority to condemn a system. Whenever the code official determines that any system, or portion thereof, regulated by this code has become hazardous to life, health or property or has

become insanitary, the code official shall order in writing that such system either be removed or restored to a safe or sanitary condition. A time limit for compliance with such order shall be specified in the written notice. No person shall use or maintain a defective system after receiving such notice.

When such a system is to be disconnected, written notice as prescribed in Section 107.2 shall be given. In cases of immediate danger to life or property, such disconnection shall be made immediately without such notice.

107.7.2 Authority to disconnect service utilities. The code official shall have the authority to authorize disconnection of utility service to the aquatic vessel regulated by the technical codes in case of an emergency, where necessary, to eliminate an immediate danger to life or property. Where possible, the owner and occupant of the building where the aquatic vessel is located shall be notified of the decision to disconnect utility service prior to taking such action. If not notified prior to disconnecting, the owner or occupant of the building shall be notified in writing, as soon as practical thereafter.

107.7.3 Connection after order to disconnect. No person shall make connections from any energy, fuel, power supply or water distribution system or supply energy, fuel or water to any equipment regulated by this code that has been disconnected or ordered to be disconnected by the code official or the use of which has been ordered to be discontinued by the code official until the code official authorizes the reconnection and use of such equipment.

When any system is maintained in violation of this code, and in violation of any notice issued pursuant to the provisions of this section, the code official shall institute any appropriate action to prevent, restrain, correct or abate the violation.

SECTION 108 MEANS OF APPEAL

108.1 Application for appeal. Any person shall have the right to appeal a decision of the code official to the board of appeals. An application for appeal shall be based on a claim that the true intent of this code or the rules legally adopted there under have been incorrectly interpreted, the provisions of this code do not fully apply, or an equally good or better form of construction is proposed. The application shall be filed on a form obtained from the code official within 20 days after the notice was served.

108.2 Membership of board. The board of appeals shall consist of five members appointed by the chief appointing authority as follows: one for 5 years, one for 4 years, one for 3 years, one for 2 years and one for 1 year. Thereafter, each new member shall serve for 5 years or until a successor has been appointed.

108.2.1 Qualifications. The board of appeals shall consist of five individuals, one from each of the following professions or disciplines:

1. Registered design professional who is a registered architect; or a builder or superintendent of building construction with at least 10 years' experience, 5 years of which shall have been in responsible charge of work.
2. Registered design professional with structural engineering or architectural experience.
3. Registered design professional with mechanical and plumbing engineering experience; or a mechanical and plumbing contractor with at least 10 years' experience, 5 years of which shall have been in responsible charge of work.
4. Registered design professional with electrical engineering experience; or an electrical contractor with at least 10 years' experience, 5 years of which shall have been in responsible charge of work.
5. Registered design professional with aquatic vessel experience; or a contractor with at least 10 years' experience, 5 years of which shall have been in responsible charge of work.

108.2.2 Alternate members. The chief appointing authority shall appoint two alternate members who shall be called by the board chairman to hear appeals during the absence or disqualification of a

member. Alternate members shall possess the qualifications required for board membership, and shall be appointed for 5 years or until a successor has been appointed.

108.2.3 Chairman. The board shall annually select one of its members to serve as chairman.

108.2.4 Disqualification of member. A member shall not hear an appeal in which that member has any personal, professional or financial interest.

108.2.5 Secretary. The chief administrative officer shall designate a qualified clerk to serve as secretary to the board. The secretary shall file a detailed record of all proceedings in the office of the chief administrative officer.

108.2.6 Compensation of members. Compensation of members shall be determined by law.

108.3 Notice of meeting. The board shall meet upon notice from the chairman, within 10 days of the filing of an appeal or at stated periodic meetings.

108.4 Open hearing. All hearings before the board shall be open to the public. The appellant, the appellant's representative, the code official and any person whose interests are affected shall be given an opportunity to be heard.

108.4.1 Procedure. The board shall adopt and make available to the public through the secretary procedures under which a hearing will be conducted. The procedures shall not require compliance with strict rules of evidence, but shall mandate that only relevant information be received.

108.5 Postponed hearing. When five members are not present to hear an appeal, either the appellant or the appellant's representative shall have the right to request a postponement of the hearing.

108.6 Board decision. The board shall modify or reverse the decision of the code official by a concurring vote of three members.

108.6.1 Resolution. The decision of the board shall be by resolution. Certified copies shall be furnished to the appellant and to the code official.

108.6.2 Administration. The code official shall take immediate action in accordance with the decision of the board.

108.7 Court review. Any person, whether or not a previous party of the appeal, shall have the right to apply to the appropriate court for a writ of certiorari to correct errors of law. Application for review shall be made in the manner and time required by law following the filing of the decision in the office of the chief administrative officer.

CHAPTER 2

DEFINITIONS

SECTION 201 GENERAL

201.1 Scope. Unless otherwise expressly stated, the following words and terms shall, for the purposes of this code, have the meanings shown in this chapter.

201.2 Interchangeability. Words used in the present tense include the future; words stated in the masculine gender include the feminine and neuter; the singular number includes the plural and the plural, the singular.

201.3 Terms defined in other codes. Where terms are not defined in this code and are defined in the *International Building Code, International Energy Conservation Code, International Fire Code, International Fuel Gas Code, International Mechanical Code, International Plumbing Code* or *International Residential Code*, such terms shall have the meanings ascribed to them as in those codes.

201.4 Terms not defined. Where terms are not defined through the methods authorized by this section, such terms shall have ordinarily accepted meanings such as the context implies.

SECTION 202 DEFINITIONS

ACCESSIBLE. Signifies access that requires the removal of an access panel or similar removable obstruction.

ACCESSIBLE, READILY. Signifies access without the necessity for removing a panel or similar obstruction.

ACTIVITY POOL. Any pool designed primarily for play activity that uses constructed features and devices including lily pad walks, flotation devices, small slide features, and similar attractions.

AIR CONTROL. A means for spas and hot tubs to regulate air flow in the air induction system, increasing or decreasing hydrotherapy action.

AIR INDUCTION SYSTEM. A system whereby a volume of air is introduced into hollow ducting built into a spa floor, bench, or hydrotherapy jets.

AIR SWITCH SYSTEM. An isolated device that utilizes a pulse of air sent down a tube to remotely operate electrical equipment.

ALTERATION. Any construction or renovation to an existing aquatic vessel other than repair that requires a permit.

APPROVED. Acceptable to the code official or authority having jurisdiction.

APPROVED AGENCY. An established and recognized agency regularly engaged in conducting tests or furnishing inspection services, when such agency has been approved by the code official

AQUATIC RECREATION FACILITY. A facility that is designed for free-form aquatic play and recreation. The facilities may include, but are not limited to, wave or surf action pools, leisure rivers, sand bottom pools, vortex pools, activity pools, inner tube rides and body slides, and interactive play attractions.

AQUATIC VESSEL. Any vessel, permanent or temporary, intended for swimming, bathing, or wading and that is designed and manufactured to be connected to a circulation system. Portable vessels 12 inches or less in designed water depth which are drained and filled daily are not considered aquatic vessels. For purposes of this code, the term is used to identify all the types of vessels governed by this code, including: swimming pools, aquatic facilities, spas and hot tubs, and related equipment. Such vessels are either used in a residential application or in a public application.

BACKWASH. The process of cleansing the filter medium and/or elements by the reverse flow of water through the filter.

BACKWASH CYCLE. The time required to backwash the filter medium and/or elements and to remove debris in the filter vessel.

BACKWASH RATE. The rate of water flow through the filter media per unit of area of effective filter area.

BALANCE. In pools and spas, used to refer to a condition of the water that is neither scaling or corrosive.

BARRIER. A permanent fence, wall, building wall, or combination thereof that completely surrounds the aquatic vessel and obstructs the access to the vessel. Permanent shall mean “not being able to be removed, lifted, or relocated without the use of a tool.”

BATHER. Any person using a pool, spa, or hot tub and adjoining deck area for the purpose of water sports, recreation, therapy or related activities.

BATHER LOAD. The number of persons in the pool/spa water at any given moment or during any stated period of time.

BEACH ENTRY. Sloping entry starting above the water line at deck level and ending below the water line. The presence of sand is not required. Also called “zero entry.”

BOOSTER PUMP SYSTEM. A pump that is completely independent of the filtration and heating system which is used to provide support for hydrotherapy jets, cleaning systems, and gas chlorinators, or special water features.

CARTRIDGE. A replaceable porous element designed to retain suspended particles from water.

CARTRIDGE FILTER. A filter that utilizes a porous element that acts as a filter medium.

CHEMICAL FEEDER. A device (floating or mechanical) for adding a chemical to pool or spa water.

CHEMICAL FEEDER OUTPUT RATE. Amount of chemical or active ingredient delivered by a feeder per unit time.

CIRCULATION EQUIPMENT. The components of a circulation system.

CIRCULATION SYSTEM. The mechanical components that are a part of a re-circulation system on a pool or spa. Circulation equipment may be, but is not limited to, categories of pumps, hair and lint strainers, filters, valves, gauges, meters, heaters, surface skimmers, inlet/outlet fittings, and chemical feeding devices. The components have separate functions, but when connected to each other by piping, perform as a coordinated system for purposes of maintaining pool or spa water in a clear and sanitary condition.

CODE OFFICIAL. The officer or other designated authority charged with the administration and enforcement of this code, or a duly authorized representative.

COMPETITIVE DIVING EQUIPMENT. Competitive diving equipment includes diving boards and adjustable fulcrum-setting diving stands as well as platforms with protective surfaces intended for competitive diving.

CONSTRUCTION DOCUMENTS. Written, graphic and pictorial documents prepared or assembled for describing the design, location and physical characteristics of the elements of a project necessary for obtaining a building permit.

COVER. A device that covers, protects, or shelters a pool, spa, or hot tub. Types of covers are:

SAFETY COVER. A barrier intended to be completely removed before entry of users for swimming pools, spas, hot tubs or wading pools, attendant appurtenances and/or anchoring mechanisms that will, when properly labeled, installed, used, and maintained in accordance with the manufacturer's published instructions. These covers are either a power or manual type.

SOLAR COVER. A cover that when placed on a pool or spa surface increases the water temperature by solar activity and reduces evaporation and heat loss.

THERMAL COVER. An insulating cover used to prevent evaporation and heat loss from pools or spas.

WINTER COVER. A cover that is secured around the perimeter of a pool or spa that provides a barrier to debris, when the pool or spa is closed for the season.

CROSS CONNECTION. An unprotected connection between domestic water supply and pool water or other non potable water where a contamination of the domestic system could occur.

DEEP AREA. Water depth areas exceeding five feet (1.52 meters).

DESIGN RATE OF FLOW. The rate of flow used for design calculations in a system.

DESIGN WATERLINE. The centerline of the skimmer or other point as defined by the design professional.

DIVING AREA. The area of a swimming pool that is designed for diving.

DIVING BOARD. A flexible board secured at one end that is used for diving such as a spring board or a jump board.

DIVING PLATFORM. Stationary platform designed for diving.

DIVING STAND. Any supporting device for a springboard, jump board or diving board.

EFFECTIVE FILTER AREA. Total surface area through which designed flow rate will be maintained during filtration.

ENTRY POOL. Pool at a water theme park that is provided at the entrance of a water slide or inner tube ride.

EQUALIZER LINE. A pipe between two pools/spas to equalize water levels.

EXERCISE SPA (Also known as a swim spa) - Variants of a spa in which the design and construction includes specific features and equipment to produce a water flow intended to allow recreational physical activity including, but not limited to, swimming in place. Exercise spas may include peripheral jetted seats

intended for water therapy, heater, circulation and filtration system, or may be a separate distinct portion of a combination spa/exercise spa and may have separate controls. These aquatic vessels are of a design and size such that it has an unobstructed volume of water large enough to allow the 99th Percentile Man as specified in ASME A112.19.8 to swim or exercise in place.

EXISTING AQUATIC VESSEL. An aquatic vessel constructed prior to the date of adoption of this code, or one for which a legal building permit has been issued.

FILTER. A device that removes undissolved particles from water by recirculating the water through a porous substance (a filter medium or elements).

FILTER CYCLE. The operating time between cleaning or backwash cycles.

FILTRATION. The process of removing undissolved particles from water by recirculating the water through a porous substance (a filter medium or elements).

FILTRATION FLOW. The design rate of flow, in volume per time through the filter system installed per manufacturer's instructions with a new, clean filter medium.

FILTRATION RATE. The rate of water flowing through a filter during a given period of time.

FIREMAN'S SWITCH: A mechanism adapted to the time clock that will turn the heater off long enough for it to cool down before the time clock turns the pump off.

FLOOD HAZARD AREA. The greater of the following two areas:

1. The area within a flood plain subject to a 1-percent or greater chance of flooding in any year.
2. The area designated as a flood hazard area on a community's flood hazard map, or otherwise legally designated.

FLUME. A trough-like or tubular structure, generally recognized as a water slide, that directs the path of travel and the rate of descent by the rider.

FLUME SLIDE. Slides of various configurations that are characterized by having deep riding channels, vertical and lateral curves, high water flows, and accommodate riders using or not using mats, tubes, rafts, and other transport vehicles. Included but not limited to family raft rides, inner-tube rides, body slides, and speed slides.

GRABBAR. Rails used to enter or leave a pool or spa.

GUTTER. Overflow trough in the perimeter wall of a pool that is a component of the circulation system or flows to waste.

HAIR AND LINT STRAINER. A device attached on or in front of a pump to which the influent line (suction line) is connected for the purpose of entrapping lint, hair, or other debris that could damage the pump.

HANDRAIL. A support device that is intended to be gripped by a user for the purpose of resting or steadying, typically located within or at exits to the pool or spa or as part of a set of steps.

HYDROSTATIC RELIEF VALVE. A fitting installed in the bottom of the pool that is designed to open automatically or manually to relieve upward ground water pressure by allowing water to flow into the pool or spa.

HYDROTHERAPY JET. A fitting that blends air and water, creating a high-velocity turbulent stream of air-enriched water.

INLET FITTING. A pipe that allows water to enter a pool, spa, or hot tub.

INTERMEDIATE POOL. Any section of a quiescent water flow between the entry and landing pools in attractions at a waterpark that utilize a series of pools.

JUMP BOARD. A manufactured diving board that has a coil spring, leaf spring, or comparable device located beneath the board that is activated by the force exerted by jumping on the board's end.

JURISDICTION. The governmental unit that has adopted this code under due legislative authority.

LABEL. An identification applied on a product by the manufacturer that contains the name of the manufacturer, the function and performance characteristics of the product or material, and the name and identification of an approved agency and that indicates that the representative sample of the product or material has been tested and evaluated by an approved agency.

LABELED. Equipment, materials or products to which has been affixed a label, seal, symbol or other identifying mark of a nationally recognized testing laboratory, inspection agency or other organization concerned with product evaluation that maintains periodic inspection of the production of the above-labeled items and whose labeling indicates either that the equipment, material or product meets identified standards or has been tested and found suitable for a specified purpose.

LADDER: A structure for ingress/egress that usually consists of two long parallel side pieces joined at intervals by crosspieces (treads).

TYPE A "A" FRAME LADDER. An entry ladder that straddles an aboveground/onground pool wall and is either removable or has a built-in entry limiting feature.

TYPE A DOUBLE ACCESS LADDER. An "A-Frame" ladder that straddles the pool wall of an aboveground pool and provides ingress and egress and is intended to be removed when not in use.

TYPE B LIMITED ACCESS LADDER. An "A-Frame" ladder that straddles the pool wall of an aboveground/onground pool. Type B ladders are removable and have a built-in feature that prevents entry to the pool when the pool is not in use.

TYPE C LADDER. A "ground to deck" staircase ladder that allows access to an aboveground pool deck and has a built-in entry-limiting feature.

TYPE D IN POOL LADDER. Located in the pool to provide a means of ingress and egress from the pool to the deck.

TYPE E or F IN POOL STAIRCASE LADDER. Located in the pool to provide a means of ingress and egress from the pool to the deck.

LANDING POOL. Pool at a waterpark that is located at the end of a flume that is designed to safely receive the rider of an attraction.

LIFELINE. An anchored line thrown to aid in rescue.

LISTED. Equipment, materials, products or services included in a list published by an organization acceptable to the code official and concerned with evaluation of products or services that maintains periodic inspection of production of listed equipment or materials or periodic evaluation of services and whose listing states either that the equipment, material, product or service meets identified standards or has been tested and found suitable for a specified purpose.

MAIN DRAIN. A submerged suction outlet to conduct water to the recirculating pump.

NEGATIVE EDGE. See *vanishing edge*.

NON-ENTRY AREA. Area of the deck from which entry into the vessel is not permitted

NON-SWIMMING AREA. Any portion of a pool where water depth, off-set ledges, or other irregularities prevent normal swimming activities.

ONGROUND STORABLE POOL. A pool which can be disassembled for storage or transport. This includes portable pools with flexible/nonrigid walls that achieve their structural integrity by means of uniform shape, support frame or a combination thereof, and can be disassembled for storage or relocation.

OUTLET FITTING. The aperture or fitting through which the water flows from the pool, spa, or hot tub.

OVERFLOW GUTTER. The gutter around the top perimeter of the pool/spa, which is used to skim the surface

OVERFLOW SYSTEM. Refers to removal of pool/spa surface water through the use of overflows and surface water collection systems of various design and manufacture.

OWNER. Any person, agent, firm or corporation having a legal or equitable interest in the property

PERMANENT SWIMMING POOL. A pool that is constructed in the ground or in a building in such a manner that it cannot be readily disassembled for storage.

PERMIT. An official document or certificate issued by the authority having jurisdiction that authorizes performance of a specified activity.

POWER SAFETY COVER. A pool cover that is placed over the water area, and is opened and closed with a motorized mechanism activated by a control switch.

PUMP STRAINER. A device, placed on the suction side of a pump that contains a removable strainer basket designed to trap debris in the water flow with a minimum of flow restriction. Also referred to as a hair/lint pot or trap.

PUBLIC POOL. Any pool, other than a residential pool, that is intended to be used for swimming or bathing and is operated by an owner, lessee, operator, licensee, or concessionaire, regardless of whether a fee is charged for use. Public pools shall be further classified and defined as follows:

CLASS A, COMPETITION POOL. Any pool intended for use for accredited competitive aquatic events such as Federation Internationale De Natation (FINA), USA Swimming, USA Diving, USA Synchronized Swimming, USA Water Polo, National Collegiate Athletic Association (NCAA), National Federation of State High School Associations (NFHS). The use of the pool is not limited to competitive events.

CLASS B, PUBLIC POOL. Any pool intended for public recreational use.

CLASS C, SEMI-PUBLIC POOL. Any pool operated solely for and in conjunction with lodgings such as hotels, motels, apartments, condominiums.

CLASS D-1, WAVE ACTION POOL. A pool designed to simulate breaking or cyclic waves for purposes of general play or surfing.

CLASS D-2, ACTIVITY POOL. A pool designed for casual water play ranging from simple splashing activity to the use of attractions placed in the pool for recreation.

CLASS D-3, CATCH POOL. A body of water located at the termination of a manufactured waterslide attraction. The body of water is provided for the purpose of terminating the slide action and providing a means for exit to a deck or walkway area.

CLASS D-4, LEISURE RIVER. A manufactured stream of water of near-constant depth in which the water is moved by pumps or other means of propulsion to provide a river-like flow that transports bathers over a defined path that may include water features and play devices.

CLASS D-5, VORTEX POOL. A circular pool equipped with a method of transporting water in the pool for the purpose of propelling riders at speeds dictated by the velocity of the moving stream of water.

CLASS D-6, INTERACTIVE PLAY ATTRACTION. A manufactured water play device or a combination of water-based play devices in which water flow volumes, pressures, or patterns can be varied by the bather without negatively influencing the hydraulic conditions for other connected devices. These attractions incorporate devices or activities such as slides, climbing and crawling structures, visual effects, user-actuated mechanical devices and other elements of bather-driven and bather-controlled play.

CLASS D-7, AMUSEMENT PARK ATTRACTION. An attraction or ride traditionally found in amusement parks that are designed to permit bather contact with water.

CLASS D-8, NATURAL BODY OF WATER. A natural or man-made aquatic play area normally regarded as oceans, lakes, ponds, streams, quarries, or bodies of water that the local jurisdiction has designated as natural bodies of water.

CLASS E. Pools used for instruction, play or therapy and with temperatures above 86° F.

Public pools are either a diving or non-diving type. Diving types of public pools are classified into types as an indication of the suitability of a pool for use with diving equipment.

TYPE VI-IX. Public pools suitable for the installation of diving equipment by type.

TYPE O. A non-diving public pool.

RECESSED TREADS. A series of vertically spaced cavities in a pool/spa wall creating tread areas for step holes.

RECIRCULATION SYSTEM. See *circulation system*.

REMODEL. To install cosmetic changes, accessory add-ons, or modernizations.

RENOVATE. A material alteration. The activity of restoring all or part of an aquatic vessel and its component parts including the rebuilding and/or replacing of worn and broken components. See remodel.

REPAIR. The restoration to good or sound condition of any part of an aquatic vessel for the purpose of its maintenance.

RESIDENTIAL. For purposes of this code, residential applies to detached one and two family dwellings and townhouses not more than three stories in height.

RESIDENTIAL POOL. Any pool intended for use which is accessory to a residential setting and available only to the household and its guests. All other pools shall be considered public pools for purposes of this code.

TYPES I –V. Residential pools suitable for the installation of diving equipment by type.

TYPE O. A non-diving residential pool.

RETURN INLET. The aperture or fitting through which the water under positive pressure returns into a pool

RIMFLOW OVERFLOW SYSTEM. Perimeter overflow system in which the overflow rim is at the same elevation as the deck.

RING BUOY. A ring-shaped floating buoy capable of supporting a user, usually attached to a throwing line.

ROPE AND FLOAT LINE. A continuous line not less than one-fourth inch in diameter that is supported by buoys and attached to opposite sides of a pool to separate the deep and shallow ends.

RUNOUT. A continuation of the water slide flume surface where riders are intended to decelerate and/or come to a stop.

SEAT (UNDERWATER). An underwater ledge that is placed completely inside the perimeter shape of the pool, generally located in the shallow end of the pool.

SHALL. The term, when used in the code, is construed as mandatory.

SHALLOW AREAS. Portions of a pool or spa with water depths less than five feet.

SKIMMER. A device installed in the pool or spa that permits the removal of floating debris and surface water to the filter.

SKIMMER COVER. A removable lid to close deck opening to the skimmer housing.

SKIMMER EQUALIZER PIPE. Connection from skimmer housing to the pool, spa, or hot tub below the weir and sized to satisfy pump demand and prevent air lock or pump loss of prime.

SLIP-RESISTANT. A surface that has been so treated or constructed to significantly reduce the chance of a user slipping. The surface shall not be an abrasion hazard.

SLOPE BREAK. Occurs at the point where the slope of the pool floor changes to a greater slope.

SPA. A product intended for the immersion of persons in temperature controlled water circulated in a closed system, and not intended to be drained and filled with each use. A spa usually includes a filter, a heater (electric, solar, or gas), a pump or pumps, and a control, and may also include other equipment, such as lights, blowers, and water sanitizing equipment.

PERMANENT RESIDENTIAL SPA. A spa, intended for use that is accessory to a residential setting and available to the household and its guests and where the water heating and water circulating equipment is not an integral part of the product. The spa is intended as a permanent plumbing fixture and not intended to be moved.

PORTABLE RESIDENTIAL SPA. A spa intended for use that is accessory to a residential setting and available to the household and its guests and where it is either self contained or non self contained.

PUBLIC SPA. Any spa other than a permanent residential spa or residential portable spa which is intended to be used for bathing and is operated by an owner, licensee, concessionaire, regardless of whether a fee is charged for use.

SELF CONTAINED SPA. A factory built spa in which all control, water heating and water circulating equipment is an integral part of the product. Self-contained spas may be permanently wired or cord connected.

NON SELF CONTAINED SPA. A factory built spa in which the water heating and circulating equipment is not an integral part of the product. Non-self-contained spas may employ separate components such as an individual filter, pump, heater and controls, or they may employ assembled combinations of various components.

SPRAY POOL. A pool or basin occupied by constructed features that spray water in various arrays for the purpose of wetting the persons playing in the spray streams.

SUCTION OUTLET. See *outlet fitting*.

SURFACE SKIMMING SYSTEM. A device or system installed in the pool/spa that permits the removal of floating debris and surface water to the filter.

SURGE. Displacement of water in a pool, either static or dynamic.

SURGE CAPACITY. The storage volume in a surge tank, gutter, and plumbing lines. See *system capacity*.

SURGE TANK. A storage vessel within the pool recirculating system used to contain the water displaced by bathers.

SWIMMING POOL. See *public pool* and *residential pool*.

SWIMOUT. An underwater seat area that is placed completely outside of the perimeter shape of the pool. Where located at the deep end, swimouts are permitted to be used as the deep-end means of entry/exit of the pool.

TSUNAMI POOL. A wave pool designed to generate a single transitional wave in each cycle. These pools are characterized by strong cross currents and counter currents after the passage of each wave. The operating pattern for the Tsunami pool produces a single wave form at frequencies ranging from several seconds to several minutes.

TUBE RIDE. A gravity flow attraction found at a waterpark designed to convey riders on an inner tube-like device through a series of chutes, channels, flumes, or pools.

TURNOVER RATE. The period of time (usually in hours) required to circulate a volume of water equal to the pool or spa capacity.

UNDERWATER LEDGE. A narrow shelf projecting from the side of a vertical structure whose dimensions are defined in the appropriate standard.

VACUUM FILTER. A filter through which water is pulled by a pump mounted on the effluent side of the filter.

VANISHING EDGE. Water-feature detail in which water flows over the edge of at least one of the pool walls and is collected in a catch basin. Also called "negative edge".

VENTURI JET. See *hydrotherapy jet*

VENTURI TUBE. A tube mounted in a circulation line so as to cause restrictions of flow. The restriction causes a pressure differential that is used to measure flow rate or to operate hydraulic chemical feeders such as sanitizers, clarifiers, etc.

WATERLINE. See *design waterline*

WAVE POOL CAISSON. A large chamber used in wave generation. This chamber houses pulsing water and air surges in the wave generation process and is not meant for human occupancy.

ZERO ENTRY. See *beach entry*

CHAPTER 3

GENERAL COMPLIANCE

SECTION 301 GENERAL

301.1 Scope. The provisions of this chapter shall govern the general design and construction of public and residential aquatic vessels and all related piping, equipment, and materials. Provisions that are unique to a specific type of aquatic vessel are located in Chapters 4 through 10.

301.1.1 Application of Chapters 4 through 10. Where differences occur between the provisions of this chapter and the provisions of Chapters 4 through 10, the provisions of Chapter 4 through 10 shall apply.

SECTION 302 ELECTRICAL, PLUMBING, MECHANICAL AND FUEL GAS REQUIREMENTS

302.1 Electrical. Electrical requirements for aquatic facilities shall be in accordance with NFPA 70 or the *International Residential Code*, as applicable in accordance with Section 102.7.1.

Exception: Internal wiring for portable residential spas and portable residential exercise spas.

302.2 Water service and drainage. Piping and fittings used for water service, makeup and drainage piping for aquatic vessels shall comply with the *International Plumbing Code*. All fittings shall be approved for installation with the piping installed.

302.3 Pipe, fittings and components. Pipe, fittings and components shall be listed and labeled in accordance with NSF 50 or NSF 14. Plastic jets, fittings, and outlets used in public spas shall be listed and labeled in accordance with NSF 50.

Exception: Portable residential spas and portable residential exercise spas listed and labeled in accordance with UL 1563 or CSA C22.2 No. 218.1.

302.4 Concealed piping inspection. All piping, including process piping, that is installed in trenches, shall be inspected prior to backfilling.

302.5 Backflow protection. Water supplies for aquatic vessels shall be protected against backflow in accordance with the *International Plumbing Code* or the *International Residential Code*, as applicable in accordance with Section 102.7.1.

302.6 Wastewater discharge. Where wastewater from aquatic vessels, backwash from filters and water from deck drains discharge to the building drainage system, such installation shall be in accordance with the *International Plumbing Code* or the *International Residential Code*, as applicable in accordance with Section 102.7.1.

302.7 Tests. Tests on piping systems constructed of plastic piping shall not use compressed air for the test.

302.8 Maintenance. Aquatic vessels shall be maintained in a clean and sanitary condition, and in good repair.

302.8.1 Manuals. An operating and maintenance manual in accordance with industry-accepted standards shall be provided for each piece of equipment requiring maintenance.

[E] SECTION 303 ENERGY

303.1 General. The energy requirements for all pools and inground permanently installed spas shall be as specified in Sections 303.2 through 303.4 and APSP 15. The energy requirements for residential portable electric spas shall be in accordance with APSP 14.

303.2 Heaters. Heaters shall be equipped with an external on-off switch to allow the heater to be shutoff without adjusting the thermostat setting. Such switch shall be provided with ready access. Gas fired heaters shall not be equipped with continuous pilot burners.

Exception: Portable residential spas and portable residential exercise spas.

303.3 Time switches. Time switches or other control methods that can automatically turn off and on heaters and pumps according to a preset schedule shall be installed on all heaters and pumps. Heaters, pumps and motors that have built in timers shall be deemed in compliance with this requirement.

Exceptions:

1. Where public health standards require 24-hour pump operation.
2. Pumps that operate solar-and waste-heat recovery pool heating systems.
3. Portable residential spas and portable residential exercise spas.

303.4 Covers. Heated pools and inground permanently installed spas shall be provided with a vapor retardant cover.

Exception: Where more than 70 percent of the energy for heating, computed over an operating season, is from site-recovered energy such as from a heat pump or solar energy source.

SECTION 304 FLOOD HAZARD AREAS

304.1 General. The provisions of section 304 shall control the design and construction of aquatic vessels installed in flood hazard areas.

304.2 Determination of impacts based on location. Aquatic vessels located in flood hazard areas established by the *International Building Code* shall comply with Section 304.2.1 or 304.2.2.

Exception: Aquatic vessels located in riverine flood hazard areas that are outside of designated floodways and aquatic vessels located in flood hazard areas where the source of flooding is tides, storm surges, or coastal storms.

304.2.1 Aquatic vessels located in designated floodways. Where aquatic vessels are located in designated floodways, documentation shall be submitted to the code official that demonstrates that the construction of the aquatic vessel will not increase the design flood elevation at any point within the jurisdiction.

304.2.2 Aquatic vessels located where floodways have not been designated. Where aquatic vessels are located where design flood elevations are specified but floodways have not been designated, the applicant shall provide a floodway analysis that demonstrates that the proposed aquatic vessel and any associated grading and filling, will not increase the design flood elevation more than 1 foot (305 mm) at any point within the jurisdiction.

304.3 Aquatic vessels in flood hazard areas subject to high velocity wave action. Aquatic vessels installed in flood hazard areas subject to high velocity wave action (coastal high hazard areas) shall be designed and constructed in accordance with ASCE 24.

304.4 Protection of equipment. Equipment shall be elevated to or above the design flood elevation or be anchored to prevent flotation and protected to prevent water from entering or accumulating within the components during conditions of flooding.

304.5 GFCI protection. Electrical equipment installed below the design flood elevation shall be supplied by branch circuits that have ground-fault circuit interrupter protection for personnel.

SECTION 305 BARRIER REQUIREMENTS

305.1 General. The provisions of this section shall apply to the design of barriers for all aquatic vessels. These design controls are intended to provide protection against the potential drowning and near drowning by restricting access to such vessels. These requirements provide an integrated level of protection against potential drowning through the use of physical barriers and warning devices.

Exception: Portable residential spas and portable residential exercise spas.

305.2 Outdoor Swimming Pools. All outdoor aquatic vessels shall be surrounded by a barrier that complies with Sections 305.2.1 through 305.8.

Exception: Spas or hot tubs with a lockable safety cover that complies with ASTM F1346.

305.2.1 Barrier height and clearances. The top of the barrier shall be at least 48 inches (1524 mm) above grade measured on the side of the barrier that faces away from the aquatic vessel around the entire perimeter of the vessel and for a distance of three (3) feet measured horizontally from the required barrier. The maximum vertical clearance between grade and the bottom of the barrier shall be 2 inches (51 mm) from surfaces that are not solid, such as grass or gravel, and measured on the side of the barrier that faces away from the vessel. Where the top of the vessel structure is above grade, the barrier shall be at ground level or mounted on top of the vessel structure, and the maximum vertical clearance between the top of the vessel structure and the bottom of the barrier shall be 4 inches (102 mm). The maximum vertical clearance between a surface below the barrier to a solid surface, such as concrete, and the bottom of the required barrier shall be four (4) inches (102 mm) measured on the side of the required barrier which faces away from the vessel.

305.2.2 Openings. Openings in the barrier shall not allow passage of a 4-inch-diameter (102 mm) sphere.

305.2.3 Solid barrier surfaces. Solid barriers that do not have openings shall not contain indentations or protrusions that form handholds and footholds, except for normal construction tolerances and tooled masonry joints.

305.2.4 Mesh restraining barrier/fence. Mesh fences, other than chain link fences in accordance with Section 305.2.7, shall be installed in accordance with the manufacturer's instructions and shall comply with the following:

1. The bottom of the mesh restraining fence shall be not more than 1 inch (25 mm) above the deck or installed surface or grade.

2. The maximum vertical clearance from the bottom of the mesh fence and the solid surface shall not permit the fence to be lifted more than four (4) inches (102 mm) from grade or decking.
3. The fence shall be designed and constructed so that it does not allow passage of a 4-inch sphere under any mesh panel. The maximum vertical clearance from the bottom of the mesh fence and the solid surface shall not be more than four (4) inches (102 mm) from grade or decking.
4. An attachment device shall attach each barrier section at a height not lower than 45 inches (1143 mm) above grade. Common attachment devices include, but are not limited to, devices that provide the security equal to or greater than that of a hook-and-eye-type latch incorporating a spring-actuated retaining lever such as a safety gate hook.
5. Where a hinged gate is used with a mesh barrier, the gate shall comply with Section 305.3.
6. Patio deck sleeves such as vertical post receptacles which are placed inside the patio surface shall be of a nonconductive material.
7. Mesh fences shall not be used on top of on ground residential pools.

305.2.5 Closely spaced horizontal members. Where the barrier is composed of horizontal and vertical members and the distance between the tops of the horizontal members is less than 45 inches (1143 mm), the horizontal members shall be located on the aquatic vessel side of the fence. Spacing between vertical members shall not exceed 1.75 inches (44 mm) in width. Where there are decorative cutouts within vertical members, spacing within the cutouts shall not exceed 1.75 inches (44 mm) in width.

305.2.6 Widely spaced horizontal members. Where the barrier is composed of horizontal and vertical members and the distance between the tops of the horizontal members is 45 inches (1143 mm) or more, spacing between vertical members shall not exceed 4 inches (102 mm). Where there are decorative cutouts within vertical members, spacing within the cutouts shall not exceed 1.75 inches (44 mm) in width.

305.2.7 Chain link dimensions. The maximum opening formed by a chain link fence shall be not more than 1.75 inches. Where the fence is provided with slats fastened at the top and bottom which reduces the openings, such openings shall be not more than 1.75 inches.

305.2.8 Diagonal members. Where the barrier is composed of diagonal members, the maximum opening formed by the diagonal members shall be no more than 1.75 inches (44 mm).

305.2.9 Clear Zone. There shall be a clear zone of not less than 36 inches (914 mm) around the exterior of the barrier and around any permanent structures or equipment such as pumps, filters and heaters that can be used to climb the barrier.

305.2.10 Poolside Barrier Setbacks. The aquatic vessel side of the required barrier shall be not less than twenty (20) inches from the water's edge.

305.3 Gates. Access gates shall comply with the requirements of Sections 305.3.1 through 305.3.3 and shall be equipped to accommodate a locking device. Pedestrian access gates shall open outward away from the vessel and shall be self-closing and have a self-latching device.

305.3.1 Utility or Service Gates. Gates not intended for pedestrian use, such as utility or service gates, shall remain locked when not in use.

305.3.2 Double or multiple gates. Double gates or multiple gates shall have at least one leaf secured in place and the adjacent leaf shall be secured with a self-latching device. The gate and barrier shall not have openings larger than 1/2 inch (12.7 mm) within 18 inches (457 mm) of the release mechanism.

305.3.3 Latches. Where the release mechanism of the self-latching device is located less than 54 inches (1372 mm) from grade, the release mechanism shall be located on the vessel side of the gate at least 3 inches (76 mm) below the top of the gate, and the gate and barrier shall not have openings greater than 1/2 inch (12.7 mm) within 18 inches (457 mm) of the release mechanism.

305.4 Structure wall as a barrier. Where a wall of a dwelling or structure serves as part of the barrier, doors and operable windows with a sill height of less than 48 inches, that provide direct access to the aquatic vessel through the wall shall be equipped with an alarm that produces an audible warning when the door or its screen or window, is opened. The alarm shall be listed and labeled in accordance with UL 2017. In dwellings or structures not required to be Accessible units, Type A units or Type B units, the deactivation switch shall be located 54 inches (1372 mm) or more above the threshold of the door. In dwellings or structures required to be Accessible units, Type A units or Type B units, the deactivation switch shall be located not greater than 54 inches (1372 mm) and not less than 48 inches (1219 mm) above the threshold of the door. In addition, one or more of the following additional levels of protection shall be provided:

1. The aquatic vessel shall be equipped with a power safety cover that is listed and labeled in accordance with ASTM F1346.
2. The aquatic vessel shall be provided with an underwater alarm that is listed and labeled in accordance with ASTM F2208.
3. The aquatic vessel shall be provided with a laser or infrared alarm that is listed and labeled in accordance with ASTM F2208.
4. Other means of protection, such as self-closing doors with self-latching devices, which are approved, shall be accepted provided that the degree of protection afforded is not less than the protection afforded by Items 1, 2 or 3.

305.5 Pool structure as a barrier. Where an on ground residential pool structure is used as a barrier or where the barrier is mounted on top of the pool structure, the following shall apply:

1. An onground pool wall, itself, shall be permitted to be the barrier where the pool structure is on grade and the wall is at least 48 inches (1219 mm) above grade for the entire perimeter of the pool and complies with the requirements of Section 305.3.
2. Where the means of access is a ladder or steps, the ladder or steps shall be capable of being secured, locked or removed to prevent access or the ladder or steps shall be surrounded by a barrier that meets the requirements of this section.
3. When the ladder or steps are secured, locked or removed, any opening created shall not allow the passage of a 4-inch-diameter (102 mm) sphere.
4. The barrier shall be installed in accordance with the manufacturer's instructions.

305.6 Natural barriers. In the case where the vessel area abuts the edge of a lake or other natural body of water, public access is not permitted or allowed along the shoreline, and required barriers extend to and beyond the water's edge a minimum of eighteen (18) inches, a barrier is not required between the natural body of water shoreline and the vessel.

305.7 Natural topography. Natural topography that prevents direct access to the aquatic vessel area shall include but not be limited to mountains and natural rock formations. A natural barrier approved by the governing body shall be acceptable provided that the degree of protection is not less than the protection afforded by manufactured or constructed means.

305.8 Indoor swimming pools. Walls surrounding indoor aquatic vessels shall comply with Section 305.4.

**SECTION 306
DECKS**

306.1 General. Decks shall be designed and installed in accordance with the *International Residential Code* or the *International Building Code*, as applicable in accordance with Section 102.7, except as provided in this section.

306.2 Slip resistant. Decks, ramps, coping, and similar step surfaces shall be slip resistant and cleanable. Special features in or on decks such as markers, brand insignias, and similar materials shall be slip resistant.

306.3 Stair treads and risers. Stair riser heights shall be in accordance with the *International Residential Code* or the *International Building Code*, as applicable in accordance with Section 102.7.1.

306.4 Slope. The minimum slope of decks shall be in accordance with Table 306.4 except where an alternate drainage method is provided that prevents the accumulation or pooling of water. The slope for all decks, other than wood decks, shall be not greater than 1/2 inch per foot (1 mm per 24 mm) except for ramps. The slope for wood decks shall be not greater than 1/8 inch per 1 foot (1 mm per 96 mm). Decks shall be sloped so that standing water will not be deeper than 1/8 inch (3.2 mm), 20 minutes after the cessation of the addition of water to the deck.

**TABLE 306.4
MINIMUM DRAINAGE SLOPES**

Surface	Typical minimum drainage slope (inch per foot)
Textured, hand-finished concrete	1/8 in. (1mm per 96mm)
Exposed aggregate	1/4 in. (1mm per 48mm)
Carpet	1/2 in. (1mm per 24mm)
Brick and heavy textures finished	3/8 in. (1mm per 32mm)

306.5 Gaps. Gaps shall be provided between deck boards in wood decks. Gaps shall be consistent with approved engineering methods with respect to the type of wood used and shall not cause a tripping hazard.

306.5.1 Maximum gap. The open gap between pool decks and adjoining decks or walkways, including joint material, shall be not greater than 3/4 inch (19.1 mm). The difference in vertical elevation between the pool deck and the adjoining sidewalk shall be not greater than 1/4 inch (6.4 mm).

306.6 Concrete joints. Isolation joints that occur where the pool coping meets the concrete deck shall be watertight.

306.6.1 Joints at coping. Joints that occur where the pool coping meets the concrete deck shall be installed to protect the coping and its mortar bed from damage as a result of the anticipated movement of adjoining deck.

306.6.2 Crack control. Joints in a deck shall be provided to minimize visible cracks outside of the control joints caused by imposed stresses or movement of the slab.

306.6.3 Movement control. Areas where decks join existing concrete work shall be provided with a joint to protect the pool from damage due to relative movement.

306.7 Deck edges. The edges of all decks shall be radiused, tapered, or otherwise designed to eliminate sharp corners.

306.8 Valves under decks. Valves installed in or under any deck shall be provided with access for operation, service, and maintenance as required by the *International Plumbing Code* or *International Residential Code*, as applicable in accordance with Section 102.7.1. Access covers shall be provided.

306.8.1 Hose bibbs. Hose bibbs shall be provided for rinsing down the entire deck and shall be installed in accordance with the *International Plumbing Code* or *International Residential Code*, as applicable in accordance with Section 102.7.1, and shall be located not more than 150 feet apart. Water-powered devices, such as water-powered lifts, shall have a dedicated hose bibb water source.

Exception: Residential spas shall not be required to have a hose bibbs located at 150-foot intervals, or have a dedicated hose bibb for water-powered devices.

SECTION 307 GENERAL DESIGN

307.1 General. The provisions of this section apply to all aquatic vessels.

Exception: The provisions of Sections 307.3 through 307.9 do not apply to portable residential spas and portable residential exercise spas.

307.2 Glazing in hazardous locations. Glazing in hazardous locations for residential pools and spas shall comply with the *International Residential Code*. Glazing in hazardous locations in all other occupancies shall comply with the *International Building Code*.

307.3 Materials. Aquatic vessels and all appurtenances thereto shall be constructed of materials that are nontoxic to humans and the environment; that are generally or commonly regarded to be impervious and enduring; that will withstand the design stresses; and that will provide a watertight structure with a smooth and easily cleanable surface without cracks or joints, excluding structural joints, or that will provide a watertight structure to which a smooth, easily cleaned surface/finish is applied or attached. All material surfaces that come in contact with the user shall be finished, so that they do not constitute a cutting, pinching, puncturing or abrasion hazard under casual contact and intended use.

307.3.1 Beach pools. Clean sand or similar material, where used in a beach pool environment, shall be used over an impervious surface. The sand area shall be designed and controlled so that the circulation system, maintenance, safety, sanitation, and operation of the pool are not adversely affected.

307.3.2 Compatibility. Assemblies of different materials shall be chemically and mechanically compatible for their intended use and environment.

307.4 Structural design. The structural design of aquatic vessels shall be in accordance with the *International Building Code* or *International Residential Code*, as applicable in accordance with Section 107.2.1.

307.4.1 Installation. Equipment for aquatic vessels shall be supported to prevent damage from misalignment and settling and located so as to allow access for inspection, servicing, removal and repair of component parts.

307.5 Freeze protection. In climates subject to freezing temperatures, outdoor aquatic vessel shells and appurtenances, piping, filter systems, pumps and motors, and other components shall be designed and constructed to provide protection from damage from freezing.

307.6 Surface condition. The surfaces within public aquatic vessels intended to provide footing for users shall be slip-resisting and shall not cause injury during normal use.

307.7 Colors and finishes. The colors, patterns, or finishes of the vessel interior shall not obscure objects or surfaces within the vessel.

Exception: Residential pools and spas.

307.8 Roofs or canopies. Roofs or canopies over aquatic vessels shall be in accordance with the *International Building Code* or *International Residential Code*, as applicable in accordance with Section 107.2.1 and shall be constructed so as to prevent water run-off into the aquatic vessel.

307.9 Accessibility. An accessible route to the aquatic vessel shall be provided in accordance with the *International Building Code*. Accessibility within the aquatic vessel shall be provided as required by the accessible recreational facilities provisions of the *International Building Code*.

SECTION 308 DIMENSIONAL DESIGN

308.1 Floor slope. The slope of the floor from the point of the first slope change to the deep area shall not exceed one unit vertical in three units horizontal.

Exception: Portable residential spas and portable residential exercise spas.

308.2 Walls. Walls shall intersect with the floor at an angle or a transition profile. Where a transitional profile is provided at water depths of 3 feet or less, a transitional radius shall not exceed 6 inches and shall be tangent to the wall and is permitted to be tangent to or intersect the floor.

Exception: Portable residential spas and portable residential exercise spas.

308.3 Shape. This code is not intended to regulate the shape of aquatic vessels other than to take into account the effect that a given shape will have on the safety of the occupants and to maintain the minimum required level of circulation to ensure sanitation.

308.4 Waterline. The design waterline shall have a maximum construction tolerance at the time of completion of the work of plus or minus one-fourth inch [± 6.35 mm] for aquatic vessels with adjustable weir surface skimming systems, and plus or minus one-eighth inch [± 3.175 mm] for aquatic vessels with nonadjustable surface skimming systems.

SECTION 309 EQUIPMENT

309.1 General: Equipment: All equipment shall be listed and labeled in accordance with NSF 50.

Exception: Portable residential spas and portable residential exercise spas listed and labeled in accordance with UL 1563 or CSA C22.2 No. 218.1.

SECTION 310 SUCTION ENTRAPMENT AVOIDANCE

310.1 General. Suction entrapment avoidance for aquatic vessels shall be provided in accordance with APSP 7.

Exception: Portable residential spas and portable residential exercise spas listed and labeled in accordance with UL 1563 or CSA C22.2 No. 218.1.

SECTION 311 CIRCULATION SYSTEMS

311.1 General. The provisions of this section apply to circulation systems for all aquatic vessels.

Exception: Portable residential spas and portable residential exercise spas.

311.2 System design. A circulation system consisting of pumps, piping, return inlets and outlets, filters, and other necessary equipment shall be provided for the complete circulation of water. Wading pools and spas shall have separate dedicated filtering systems.

Exception: Separate filtering systems are not required for residential aquatic vessels.

311.2.1 Turnover rate. The equipment shall be sized to turn over the volume of water that the aquatic vessel is capable of containing as specified in this code for the specific installation.

311.2.2 Servicing. Circulation system components that require replacement or servicing shall be provided with access for inspection, repair, or replacement and shall be installed in accordance with the manufacturer's specifications.

311.2.3 Equipment anchorage. Aquatic vessel equipment and related piping shall be designed and installed in accordance with the manufacturer's installation instructions.

311.3 Water velocity. The water velocity in return lines shall not exceed 8 feet per second and the water velocity in suction piping shall comply with APSP 7.

311.4 Piping and fittings. Plastic pipe and fittings used in circulation systems shall be nontoxic and shall be able to withstand the design operating pressures and conditions of the aquatic vessel. Plastic pipe shall be listed and labeled as complying with NSF 14. Circulation system piping shall be listed and labeled as complying with one of the standards in Table 311.4.

**TABLE 311.4
CIRCULATION SYSTEM PIPE**

MATERIAL	STANDARD
Acrylonitrile butadiene styrene (ABS) plastic pipe	ASTM D1527;
Copper or copper-alloy tubing	ASTM B88; ASTM B447
Polyvinyl chloride (PVC) hose	IAPMO PS-33;
Polyvinyl chloride (PVC) plastic pipe	ASTM D1785;
Chlorinated polyvinyl chloride (CPVC) plastic pipe and tubing	ASTM D2846;

311.4.1 Fittings. Fittings used in circulation systems shall be listed and labeled as complying with one of the standards in Table 311.4.1.

**TABLE 311.4.1
CIRCULATION SYSTEM FITTINGS**

MATERIAL	STANDARD
Acrylonitrile butadiene styrene (ABS) plastic pipe	ASTM D1527
Copper or copper-alloy tubing	ASME B 16.15
Polyvinyl chloride (PVC) plastic pipe	ASTM D2464; ASTM D2466; ASTM D2467; CSA B137.2; CSA B137.3
Chlorinated polyvinyl chloride (CPVC) plastic pipe and tubing	ASTM D2846; ASTM F437; ASTM F438; ASTM F439; CSA B137.6

311.4.2 Joints. Joints shall be made in accordance with manufacturer's instructions.

311.4.3 Piping subject to freezing. Piping subject to damage by freezing shall have a uniform slope in one direction and shall be equipped with valves for drainage or shall be capable of being evacuated to remove the water.

311.5 System draining. Equipment shall be designed and fabricated to drain the water from the equipment, together with exposed face piping, by removal of drain plugs, manipulating valves, or by other methods. Drainage shall be in accordance with manufacturer's specifications.

311.6 Pressure or vacuum gauge. Gauges shall be provided for public pools in the circulation system. Gauges shall be provided with ready access.

1. A pressure gauge shall be located downstream of the pump and between the pump and filter.
2. A vacuum gauge shall be located between the pump and filter and upstream of the pump.

311.7 Flow Measurement. Public swimming pools and wading pools shall be equipped with a flow-measuring device that indicates the rate of flow through the filter system. The flow rate measuring device shall indicate gallons per minute and shall be selected and installed to be accurate within plus or minus 10% of actual flow.

311.8 Instructions. Written operation and maintenance instructions shall be provided for the circulation system of public pools.

311.9 Hydrostatic pressure test. Circulation system piping, other than that integrally included in the manufacture of the aquatic vessel, shall be subjected to a hydrostatic pressure test of 25 pounds per square inch (psi). This pressure shall be held for not less than 15 minutes.

SECTION 312 FILTERS

312.1 General. The provisions of this section apply to filters for all aquatic vessels.

Exception: Portable residential spas and portable residential exercise spas.

312.2 Design. Filters shall have a flow rating equal to or greater than the design flow rate of the system. Filters shall be installed in accordance with the manufacturer's instructions. Filters shall be designed so that filtration surfaces can be inspected and serviced.

312.3 Internal pressure. For pressure-type filters, a means shall be provided to permit the release of internal pressure.

312.3.1 Air release. Any filter incorporating an automatic means of internal air release as the principal means of air release shall have one or more lids that provide a slow and safe release of pressure as a part of the design and shall have an manual air release in addition to an automatic release.

312.3.2 Separation tanks. A separation tank used in conjunction with a filter tank shall have a manual method of air release or a lid that provides for a slow and safe release of pressure as it is opened.

SECTION 313 PUMPS AND MOTORS

313.1 General. The provisions of this section apply to pumps and motors for all aquatic vessels.

Exception: Portable residential spas and portable residential exercise spas.

313.2 Performance. A pump shall be provided for circulation of the pool water. The pump shall be capable of providing the flow required for filtering the pool water and filter cleaning, if applicable, against the total dynamic head developed by the complete system.

313.3 Intake protection. A cleanable strainer, skimmer basket, or screen shall be provided for public aquatic vessels, upstream of circulation pumps, to remove solids, debris, hair, and lint on all pressure filter systems.

313.4 Location. Pumps and motors shall be accessible for inspection and service in accordance with the manufacturer's specifications.

313.5 Safety. The design, construction, and installation of pumps and component parts shall be in accordance with the manufacturer's specifications.

313.6 Isolation Valves. Shutoff valves shall be installed on the suction and discharge sides of pumps that are located below the waterline. Such valves shall be provided with access.

313.7 Emergency shutoff switch. An emergency shutoff switch shall be provided to disconnect all power to recirculation and jet system pumps and air blowers. Emergency shutoff switches shall be: provided with access; located within sight of the aquatic vessel and located not less than 5 feet (5') horizontally from the inside walls of the aquatic vessel.

Exception: Onground storable and permanent inground residential swimming pools.

313.8 Motor performance. Motors shall comply with UL 1004, UL 1081, CSA C22.2 No. 108 or the relevant motor requirements of UL 1563 or CSA C22.2 No. 218.1, as applicable.

SECTION 314 RETURN AND SUCTION FITTINGS

314.1 General. The provisions of this section apply to return and suction fittings for all aquatic vessels.

Exception: Portable residential spas and portable residential exercise spas.

314.2 Entrapment avoidance. Entrapment avoidance means shall be provided in accordance with Section 310.

314.3. Flow distribution. The main drains, where installed, and the skimming systems shall each be designed to accommodate 100 percent of the circulation turnover rate.

314.3.1 Multiple Systems. Where multiple systems are used in a single pool to meet this requirement, each subsystem shall proportionately be designed such that the maximum design flow rates cannot be exceeded during normal operation.

314.4 Return fittings. Pools shall have not less than two return fittings regardless of pool size. For pools having a surface area greater than 300 square feet, one additional return fitting shall be provided for each 300 square feet (27.87 m²) of surface area, or fraction thereof.

314.4.1 Sizing. Return fittings shall be sized to provide uniform distribution of water flow throughout the pool.

314.4.2 Design. Return and suction fittings for the circulation system shall be designed so as not to constitute a hazard to the bather.

314.4.3 Bottom returns Bottom return fittings shall be flush with the bottom or designed to minimize hazards associated with protrusions.

314.4.4 Area of influence. Bottom return fittings shall be considered to have an area of influence described by a circle with a radius of 15 feet (457 cm).

314.5 Vacuum fittings. Submerged vacuum fittings shall be prohibited.

SECTION 315 SKIMMERS

315.1 General. The provisions of this section apply to skimmers for all aquatic vessels.

Exception: Portable residential spas and portable residential exercise spas.

315.2 Required. A surface skimming system shall be provided for public aquatic vessels. Either a surface skimming system or perimeter overflow system shall be provided for permanent inground residential pools. The surface skimming system shall be designed and constructed to skim the surface when the water level is maintained within the operational parameters.

Exception: Class D public pools designed in accordance with Chapter 6.

315.2.1 Circulation system shall be designed to process a minimum of 100% of the turnover rate through skimmers.

315.3 Skimmer Sizing. Where automatic surface skimmers are used as the sole overflow system, at least one surface skimmer shall be provided for the square foot areas, or fractions there-of, noted in Table 315.3. Skimmers shall be located to maintain effective skimming action.

**TABLE 315.3
SKIMMER SIZING TABLE**

Aquatic vessel	Area per skimmer (sq. ft)
Public pool	400
Residential pool	800
Spas (all types)	150

315.4 Perimeter coverage. Where a perimeter-type surface skimming system is used as the sole surface skimming system, the system shall extend around not less than of 50% of the aquatic vessel perimeter.

315.4.1 Surge Capacity. Where perimeter surface skimming systems are used, they shall be connected to a circulation system with a system surge capacity of not less than 1 gallon for each square foot (40.7 liters per square meter) of water surface. The capacity of the perimeter overflow system and related piping is permitted to be considered as a portion of the surge capacity.

315.5 Equalizers. Equalizers on skimmers shall not be permitted.

315.6 Hazard. Skimming devices shall be designed and installed so as not to create hazard to the user.

SECTION 316 HEATERS

316.1 General. The provisions of this section apply to heaters for all aquatic vessels.

Exception: Portable residential spas and portable residential exercise spas.

316.2 Listed and labeled. Heaters shall be listed and labeled in accordance with the applicable standard listed in Table 316.2.

**TABLE 316.2
WATER HEATERS**

DEVICE	STANDARD
Electric water heater	UL 1261, UL 1563 or CSA C22.2 No. 218.1
Gas fired water heater	ANSI Z21.56a
Heat pump water heater	UL 1995, AHRI 1160
Thermal radiant solar water heater	NSF 50, FSEC Standard 102
Photovoltaic solar water heaters	NSF 50, FSEC Standard 202
Heat exchanger	NSF 50

316.3 Sizing. Heaters shall be sized in accordance with the manufacturer's specifications.

316.4 Installation. Heaters shall be installed in accordance with the manufacturer's specifications and the *International Fuel Gas Code*, *International Mechanical Code*, *International Energy Conservation Code*, NFPA 70 or *International Residential Code*, as applicable in accordance with Section 102.7.1.

316.4.1 Temperature. A means shall be provided to monitor water temperature.

316.4.2 Access prohibited. For public aquatic vessels, public access to controls shall not be allowed.

316.5 Heater circulation system. Heater circulation systems shall comply with Sections 316.5.1 and 316.5.2.

316.5.1 Water flow. Water flow through the heater bypass piping, back-siphonage protection, and the use of heat sinks shall be in accordance with the heater manufacturer's specifications.

316.5.2 Pump delay. Where required by the manufacturer, heaters shall be installed with an automatic device that will ensure that the pump continues to run after the heater shuts off for the time period specified by the manufacturer.

**SECTION 317
AIR BLOWER AND AIR INDUCTION SYSTEM**

317.1 General: This section applies to all devices and systems that induce or allow air to enter aquatic vessels either by means of a powered pump or passive design.

317.2 Backflow prevention. Air blower systems shall be equipped with backflow protection as specified in UL 1563 or CSA C22.2 No 218.1.

317.3 Air intake source. Air intake sources shall not induce water, dirt or contaminants.

317.4 Sizing. Air induction systems shall be sized in accordance with to the manufacturer's specifications.

317.5 Inspection and service. Air blowers shall be provided with access for inspection and service.

**SECTION 318
WATER SUPPLY**

318.1 Makeup water. Makeup water to maintain the water level and water used as a vehicle for sanitizers or other chemicals, for pump priming, or for other such additions, shall be from a potable water source.

318.2 Protection of potable water supply. Potable water supply systems shall be designed, installed and maintained so as to prevent contamination from nonpotable liquids, solids or gases being introduced into the potable water supply through cross-connections or any other piping connections to the system. Means of protection against backflow in the potable water supply shall be provided through an air gap complying with ASME A112.1.2 and the *International Residential Code* or the *International Plumbing Code*, as applicable in accordance with Section 102.7.1.

318.3 Over-the-Rim Spouts. Over-the-rim spouts shall be located under a diving board, adjacent to a ladder, or otherwise shielded so as not to create a hazard. The open end of such sprouts shall not have sharp edges and shall not protrude more than 2 inches (5 cm) beyond the edge of the pool. The open end shall be separated from the water by an air gap of at least 1.5 pipe diameters measured from the pipe outlet to the rim.

**SECTION 319
SANITIZING EQUIPMENT**

319.1 Equipment standards. Sanitizing equipment installed in public aquatic vessels shall be capable of introducing the quantity of sanitizer necessary to maintain the appropriate levels under all conditions of intended use.

319.2 Chemical feeders. Where installed, chemical feed systems shall be installed in accordance with the manufacturer's specifications. Chemical feed pumps shall be wired so that they cannot operate unless there is adequate return flow to disburse the chemical throughout the vessel as designed.

**SECTION 320
WASTE WATER DISPOSAL**

320.1 Backwash water or draining water. Backwash water and draining water shall be discharged to the sanitary or storm sewer, or into an approved disposal system on the premise, or shall be disposed of

by other means approved by the state or local authority. Direct connections shall not be made between the end of the backwash line and the disposal system. Drains shall discharge through an air gap.

320.2 Water salvage. Filter backwash water shall not be returned to the vessel except where the backwash water has been filtered to remove particulates, treated to eliminate coli form bacteria and waterborne pathogens, and such return has been approved by the state or local authority.

320.3 Waste post treatment. Where necessary, filter backwash water and drainage water shall be treated chemically or through the use of settling tanks to eliminate or neutralize chemicals, diatomaceous earth (DE), and contaminants in the water that exceed the limits set by the state or local effluent discharge requirements.

SECTION 321 LIGHTING

321.1 General. The provisions of this section apply to lighting for all aquatic vessels.

Exception: Portable residential spas and portable residential exercise spas.

321.2 Artificial lighting required. When a pool is open during periods of low natural illumination, artificial lighting shall be provided so that all areas of the pool, including the bottom main drains, will be visible.

321.2.1 Pool and deck illumination. Overhead or underwater lighting shall be provided to illuminate the pool and adjacent deck areas. Such lighting shall be installed in accordance with NFPA 70 or the *International Residential Code*, as applicable in accordance with Section 102.7.1.

321.2.2 Illumination Intensity. For outdoor pools, overhead lighting shall provide not less than 3 foot-candles of illumination at the pool water surface and on adjacent deck areas. For indoor pools, overhead lighting shall provide not less than of 10 foot-candles at the pool water surface.

321.2.3 Underwater lighting. Underwater lighting shall provide a minimum of 8 lumens per square foot of pool water surface area.

Exception: Underwater lighting is not required if overhead lighting provides not less than of 15 foot-candles of illumination at the pool surface.

321.3 Emergency illumination. Public pools and pool areas that operate during periods of low illumination shall be provided with sufficient emergency lighting to permit evacuation of the pool and securing of the area in the event of power failure. The emergency lighting intensity shall be not less than ½ foot candle.

SECTION 322 LADDERS AND RECESSED TREADS

322.1 General. Ladders and recessed treads shall comply with the provisions of this section and the applicable provisions of Chapters 4 through 10 based on the type of aquatic vessel.

322.2 Outside diving envelope. Where installed, steps and ladders shall be located outside of the minimum diving water envelope as indicated in Figure 322.2.

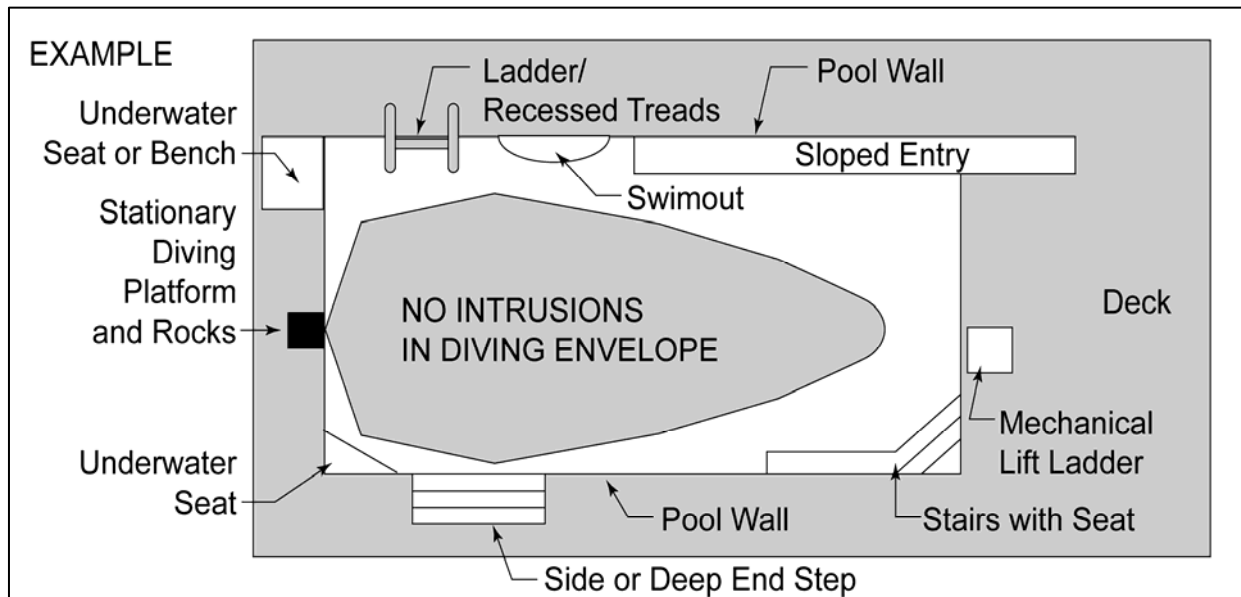

**FIGURE 322.2
MINIMUM WATER DIVING ENVELOPE**

322.3 Ladders. Ladder treads shall have a uniform horizontal depth of not less than 2 inches (51 mm). There shall be a uniform distance between ladder treads, with a distance of not less than 7 inch (178 mm) and not greater than 12 inches (305 mm). The top tread of a ladder shall be located not greater than 12 inches below the top of the deck or coping. Ladder treads shall have slip-resisting surfaces

322.3.1 Wall clearance. There shall be a clearance of not less than 3 inches (76 mm) and not greater than 6 inches (152 mm) between the pool wall and the ladder.

322.3.2 Handrails and handholds. Ladders shall be provided with two handholds or two handrails. The clear distance between ladder handrails shall be not less than 17 inches (432 mm) and not greater than 24 inches (610 mm).

322.4 Recessed treads. Recessed treads shall have minimum depth of not less than 5 inches (127 mm) and a width of not less than 12 inches (305 mm). The vertical distance between the pool coping edge, deck, or step surface and the uppermost recessed tread shall be not greater than 12 inches (305 mm). Recessed treads shall have slip-resisting surfaces.

322.4.1 Vertical Spacing. Recessed treads at the centerline shall have a uniform vertical spacing of not less than 7 inches (178 mm) and not greater than 12 inches (305 mm).

322.4.2 Drainage. Recessed treads shall drain into the pool.

322.4.3 Handrails and grabrails. Recessed treads shall be provided with a handrail or grabrail on each side of the treads. The clear distance between handrails and grabrails shall be not less than 17 inches (432mm) and not greater than 24 inches (610mm).

SECTION 323 SAFETY

323.1 Handholds required. Where the depth below the design waterline of an aquatic vessel exceeds 42 inches, handholds along the perimeter shall be provided. Handholds shall be located at the top of deck or coping

Exceptions:

1. Handholds shall not be required where an underwater bench, seat or swimout is installed.
2. Handholds shall not be required for wave action pools and action rivers.

323.1.1 Height above water. Handholds shall be located not more than 12 inches above the design waterline.

323.1.2 Handhold type. Handholds shall be one or more of the following:

1. top of pool deck or coping
2. secured rope
3. rail
4. rock
5. ledge
6. ladder
7. stair step
8. any design that allows holding on with one hand while at the side of the pool

323.1.3 Handhold spacing. Handholds shall be horizontally spaced not greater than 4 feet (2438 mm) apart.

323.2 Handrails. Where handrails are installed, they shall conform to this section.

323.2.1 Height. Handrails shall be between 34 inches (864mm) and 38 inches (965mm) above the ramp or step surface as measured at the nosing of the step or finished surface of the slope.

323.2.2 Material. Handrails shall be made of corrosion-resistant materials.

323.2.3 Non-removable. Handrails shall be installed so that they cannot be removed without the use of tools.

323.2.4 Leading edge distance. The leading edge of handrails for stairs, pool entries and exits shall be located not greater than 18 inches (457mm) from the vertical face of the bottom riser.

323.2.5 Diameter. The outside diameter or width of handrails shall be not less than 1 ¼ inches (32mm) and not greater than 2 inches (51mm).

323.3 Obstructions and entrapment avoidance. There shall not be obstructions that can cause the user to be entrapped or injured. Types of entrapment include, but are not limited to, wedge or pinch-type openings and rigid, non-giving cantilevered protrusions.

CHAPTER 4

PUBLIC SWIMMING POOLS

SECTION 401 GENERAL

401.1 Public swimming pools. The provisions of this chapter shall apply to public swimming pools. Public swimming pools covered in this chapter include Class A, Class B, Class C and Class E pools.

401.2 Scope. The requirements contained in this chapter provide specifications for the design, equipment, operation, warning signs, installation, sanitation, new construction, and alteration of public swimming pools.

401.3 General. In addition to the requirements of this chapter, public swimming pools shall also comply with the requirements of Chapter 3.

401.4 Dimensional tolerances. Finished pool dimensions, for other than Class A pools, shall be held within the construction tolerances shown in Table 401.4. Other dimensions, unless otherwise specified, shall have a tolerance of ± 2 inches (51mm).

401.4.1 Class A pool tolerances. Dimensional tolerances for Class A Pools shall be determined by the authority that governs such pools.

**TABLE 401.4
CONSTRUCTION TOLERANCES**

Design Aspect	Construction tolerance
Length – overall	± 3 in. (76 mm)
Width – overall	± 3 in. (76 mm)
Depth - deep area, including diving area	± 3 in. (76 mm)
Depth - shallow area	± 2 in. (51 mm)
Step treads & risers	$\pm 1/2$ in. (13 mm)
Waterline - pools with adjustable weir skimmers	$\pm 1/4$ in. (6 mm)
Waterline - pools with nonadjustable skimming systems (gutters)	$\pm 1/8$ in. (3 mm)
Wall slopes	± 3 degrees
All dimensions not otherwise specified herein	± 2 in. (51 mm)

401.5 Floor slope. Except where required to meet the accessibility requirements in accordance with Section 323.1, the slope of the floor in the shallow area of a pool shall not exceed 1 unit vertical in 10 units horizontal for Class C pools and 1 unit vertical in 10 units horizontal for Class B pools. The slope limit shall apply in any direction to the point of the first slope change, where a slope change exists. The point of the first slope change shall be defined as the point at which the floor slope exceeds 1 unit vertical in 10 units horizontal for Class C pools and 1 unit vertical in 10 units horizontal for Class B pools.

401.6 Dimensions for Class A Pools. Class A pools shall be designed and constructed to provide the dimensions determined by the authority that governs such pools.

SECTION 402 DIVING

402.1 General. This section covers diving requirements for Class B, Class C, and Class E pools. Manufactured and fabricated diving equipment and appurtenances shall not be installed on Type O pools.

402.2 Manufactured and fabricated diving equipment. Manufactured and fabricated diving equipment shall be in accordance with Section 808 and shall be designed for swimming pool use.

402.3 Installation. The installation of manufactured diving equipment shall be in accordance with Sections 402.3 through 402.12. Manufactured diving equipment shall be located in the deep area of the pool so as to provide the minimum dimensions shown in Table 402.12 and shall be installed in accordance with manufacturer's instructions. Installation and use instructions for manufactured diving equipment shall be provided by the manufacturer and shall specify the minimum water dimensions required for each diving board and diving stand combination. The manufacturers' instructions shall refer to the water envelope type by dimensionally relating their products to Point A on the water envelopes shown in Table 402.12. The diving board manufacturer shall specify which boards fit on the design pool geometry types as indicated in Table 402.12.

402.4 Slip-resistant. Diving equipment shall have slip-resistant walking surfaces.

402.5 Point A. For the application of Table 402.12, Point A shall be the point from which all dimensions of width, length and depth are established for the minimum diving water envelope. If the tip of the diving board or diving platform is located at a distance of WA (see Figure 804.1) or greater from the deep end wall and the water depth at that location is equal to or greater than the water depth requirement at Point A, the point on the water surface directly below the center of the tip of the diving board or diving platform shall be identified as Point A.

402.6 Location of pool features in a diving pool. Where a pool is designed for use with diving equipment, the location of steps, pool stairs, ladders, underwater benches, special features and other accessory items shall be outside of the minimum diving water envelope. See Figure 322.2

402.7 Stationary diving platforms and diving rocks. Where stationary diving platforms and diving rocks are built on site, flush with the wall and located in the diving area of the pool, point A shall be in front of the wall at the platform or diving rock centerline.

402.8 Location of diving equipment. Manufactured and fabricated diving equipment shall be located so that the tip of the board or platform is located directly above Point A as defined by Section 402.7.

402.9 Elevation. The maximum elevation of a diving board above the design waterline shall be in accordance with the manufacturer's instructions.

402.10 Platform height above waterline. The height of an approved stationary diving apparatus, platform, or diving rock above the design waterline shall not exceed the limits of the manufacturer's specifications of the limits of the design prepared by a design professional.

402.11 Clearance. The diving equipment manufacturer shall specify the minimum headroom required above the tip of the board.

402.12 Water envelopes. The minimum diving water envelopes shall be in accordance with Table 402.12.

**Table 402.12
MINIMUM DIVING WATER ENVELOPES
(See Figure 402.12)**

Pool Type	Minimum dimensions								Minimum width of pool at:		
	D ₁	D ₂	R	L ₁	L ₂	L ₃	L ₄	L ₅	Pt. A	Pt. B	Pt. C
VI	7'-0"	8'-6"	5'-6"	2'-6"	8'-0"	10'-6"	7'-0"	28'-0"	16'-0"	18'-0"	18'-0"
VII	7'-6"	9'-0"	6'-0"	3'-0"	9'-0"	12'-0"	4'-0"	28'-0"	18'-0"	20'-0"	20'-0"
VIII	8'-6"	10'-0"	7'-0"	4'-0"	10'-0"	15'-0"	2'-0"	31'-0"	20'-0"	22'-0"	22'-0"
IX	11'-0"	12'-0"	8'-6"	6'-0"	10'-6"	21'-0"	0	37'-6"	22'-0"	24'-0"	24'-0"

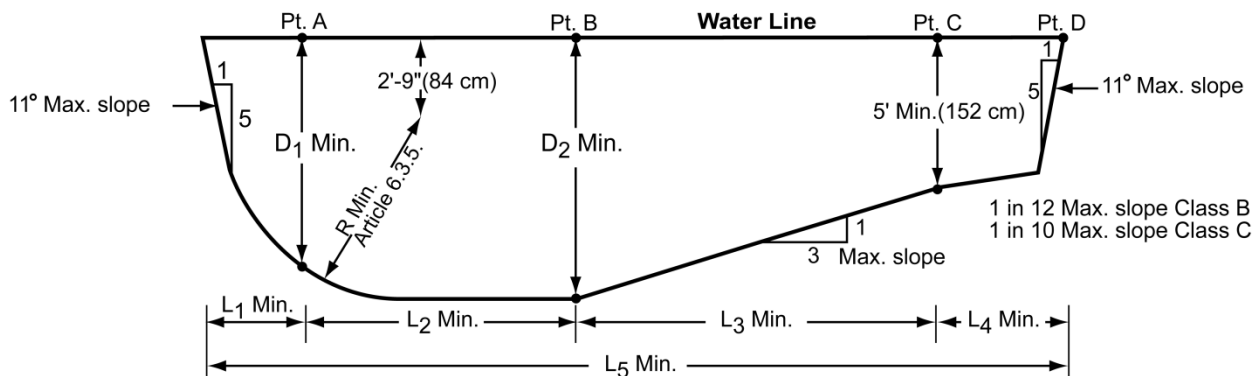

**Figure 402.12 Minimum Diving water envelopes
CONSTRUCTION DIMENSIONS FOR WATER ENVELOPES FOR CLASS B AND CLASS C POOLS**

402.13 Ladders for Diving Equipment. Ladders shall be provided with two grabrails or two handrails. There shall be a uniform distance between ladder treads, with a 7 inch (178 mm minimum) distance and 12 inch (305 mm) maximum distance.

Exception: The distance between treads for the top and bottom riser can vary.

SECTION 403 BATHER LOAD

403.1 Maximum bather load. The maximum bather load of Class B and Class C pools shall be in accordance with Table 403.1.

**TABLE 403.1
MAXIMUM BATHER LOAD**

Pool/Deck area	Shallow instructional or wading areas	Deep area (not including the diving area)	Diving area (per each diving board)
Pools with minimum deck area	15 sq. ft. per user	20 sq. ft. per user	300 sq. ft.
Pools with deck area at least equal to water surface area	12 sq. ft. per user	15 sq. ft. per user	300 sq. ft.
Pools with deck area at least twice the water surface area	8 sq. ft. per user	10 sq. ft. per user	300 sq. ft.

**SECTION 404
REST LEDGES**

404.1 Rest ledges. Rest ledges along the pool walls are permitted. They shall be not less than 4 feet (122 cm) below the water surface. Where a ledge is provided, the ledge shall be 4 inches (10 cm) minimum in width and 6 inches (15cm) maximum in width.

**SECTION 405
WADING POOLS**

405.1 Wading pools. Wading pools shall be separate pools with an independent circulation system and shall be physically separated from the main pool. Wading pools shall be constructed in accordance with Sections 405.2 through 405.6.

405.2 Non-entry areas. The areas where the water depth at the edge of the pool exceeds 9 inches (229 mm) shall be considered as non-entry areas.

405.3 Floor slope. The floors of wading pools shall be uniform and sloped with a maximum slope of 1 unit vertical in 12 units horizontal.

405.4 Maximum depth. The water depth shall not exceed 18 inches (457 mm).

405.5 Distance from deck to waterline. The maximum distance from the top of the deck to the water line shall not exceed 6 inches (152 mm).

405.6 Prohibited outlets. Submerged suction outlets shall not be permitted in wading pools.

**SECTION 406
DECKS AND DECK EQUIPMENT**

406.1 General. Decks shall comply with the provisions of Section 306, except as otherwise required in this section.

406.2 Pool perimeter access. A deck or unobstructed access shall be provided for not less than 90 percent of the pool perimeter.

406.3 Deck Clearance: Decking not less than 4 feet in width shall be provided on the sides and rear of any diving equipment. A deck clearance of 3 feet (914mm) shall be provided around all other deck equipment.

406.4 Distances above diving boards. A completely unobstructed minimum distance above the tip of the diving board shall be specified by the diving equipment manufacturer or the authority that governs such pools.

406.5 Dimensional requirements. Public pools with diving equipment of 39 inches (991mm) or greater in height, and pools designed for springboard or platform diving, shall comply with the dimensional design requirements of the diving equipment manufacturer or the authority that governs such pools.

406.6 Diving equipment. Diving equipment shall be installed in accordance with the manufacturer's specifications.

406.6.1 Label. A label shall be permanently affixed to the diving equipment or jump board in a readily visible location and shall include all of the following:

1. The minimum water envelope required for each diving board and diving stand combination.
2. Manufacturer's name and address.
3. Manufacturer's identification and date of manufacture.
4. The maximum weight of the user.

406.6.2 Use instructions. The diving equipment manufacturer shall provide diving equipment use instructions for its diving equipment.

406.6.3 Trend surface. Diving equipment shall have slip-resistant tread surfaces.

406.6.4 Supports for diving equipment. Supports, platforms, stairs, and ladders for diving equipment shall be designed to carry the anticipated loads. Stairs and ladders shall be of corrosion-resistant materials, shall be easily cleanable and shall have with slip-resistant treads. Diving stands higher than 21 inches (533 mm), measured from the deck to the top back end of the board, shall be provided with stairs or a ladder. Step treads shall be self-draining.

406.6.5 Guardrails. Diving equipment 39 inches (991mm) or greater in height shall be provided with a top guardrail. Such guardrail shall extend not less than 30 inches (762 mm) above the diving board and extend to the edge of the pool wall.

406.7 Starting blocks. In new construction or substantial alteration, starting blocks intended for competitive swimming shall be located at a water depth of not less than 5 feet (1524mm)

406.8 Swimming pool slides. Swimming pool slides shall comply with the requirements of 16 CFR, Part 1207. The manufacturer of the slide shall provide installation and use instructions for the slide. Slides shall be installed in accordance with the manufacturer's instructions.

406.9 Play and water activity equipment. Play and water activity equipment shall be installed in accordance with the manufacturer's instructions.

SECTION 407 CIRCULATION SYSTEMS

407.1 General. Circulation systems for pools shall comply with Section 311 and the provisions of this section.

407.2 Turnover. Circulation equipment shall be sized to turn over the entire water capacity of the pool as specified in Table 407.2. The system shall be designed to provide the required turnover rate based on the maximum pressure and flow rate recommended by the manufacturer for and the filter and clean filter media.

**TABLE 407.2
TURNOVER RATE**

Swimming pool category	Turnover rate In hours
Class A, B, and C pools	Hours equal 1-1/2 times the average depth of pool in feet not to exceed 6 hours
Wading pools	1

**SECTION 408
FILTERS**

408.1 General. Filters shall be designed in accordance with Section 312, except as otherwise required in this section.

408.2 Air release warning. The following statement shall be posted in a conspicuous location within the areas of the air release: “Do not start the system after maintenance without first opening the air release and properly reassembling the filter and separation tank and opening the air release valve.”

**SECTION 409
SPECIFIC SAFETY FEATURES**

409.1 Handholds. Handholds shall comply with the provisions of Section 323.

409.2 Depth markers. Depth markers shall be provided in accordance with Sections 416.2.1 through 416.2.5

409.2.1 Where required. Depth markers shall be installed at the maximum and minimum water depths and at all points of slope change. Depth markers shall be installed at intermediate increments of water depth not to exceed 2 feet (607 mm). Depth markers shall be spaced at intervals not to exceed 25 feet (7620 mm).

409.2.2 Marking of depth. The depth of water in feet shall be plainly and conspicuously marked on the vertical pool wall at or above the waterline.

Exception: Aquatic vessels with vanishing edge and rim flow gutters.

409.2.3 Depth accuracy. Depth markers shall indicate the actual pool depth within \pm 3 inches (76 mm), at normal operating water level when measured 3 feet (91 cm) from the pool wall or at the tangent point where the cove radius meets the floor, whichever is deeper.

409.2.4 Position on pool wall. Depth markers on the vertical pool wall shall be positioned to be read from the waterside. Depth markers shall be placed so as to allow as much of the numbers to be visible above the waterline as possible.

409.2.5 Position on deck. Depth markers on the deck shall be located within 18 inches (457 mm) of the water edge and positioned to be read while standing on the deck facing the water.

409.2.6 Horizontal markers. Horizontal depth markers shall be slip resistant.

409.2.7 Uniform distribution. Depth markers shall be distributed uniformly on both sides and both ends of the pool.

409.2.8 Numbers and letters. Depth markers shall be not less than 4 inches (102mm) in height. The color of the numbers shall contrast with the background on which they are applied and the color shall be of a permanent nature. The lettering shall spell out the words “feet” and “inches” or

abbreviate them as "Ft." and "In." respectively. Where displayed in meters in addition to feet and inches, the word meter shall be spelled out or abbreviated as "m".

409.3 No diving symbol. Where the pool depth is 5 feet (1524mm) or less, the "No Diving" symbol shall be displayed. The symbol shall be placed on the deck at intervals of not more than 25 feet (762 cm). Additional signage shall be in accordance with ANSI Z535.

409.4 Lifesaving equipment. Public pool Classes A, B, and C shall be provided with lifesaving equipment in accordance with sections 409.4.1 through 409.4.3. Such lifesaving equipment shall be visually conspicuous and conveniently located at all times.

409.4.1 Accessory pole. A swimming pool accessory pole not less than 12 feet in length and including a body hook shall be provided.

409.4.2 Throwing rope. A throwing rope attached to ring buoy or similar flotation device shall be provided. The rope shall be not less than ¼ inch in diameter and shall have a length of not less than 1 ½ times the maximum width of the pool or 50 feet, whichever is less. A ring buoy shall have an outside diameter is not less than 15 inches.

409.4.3 Emergency response units. Pools covered in this code shall be provided with first aid equipment, including a first aid kit. First aid equipment and kits shall be located in an accessible location.

SECTION 410 DRESSING AND SANITARY FACILITIES

410.1 Dressing and sanitary facilities. Dressing and sanitary facilities shall be provided for Class A and B pools as required by the *International Building Code* and *International Plumbing Code*.

SECTION 411 SPECIAL FEATURES

411.1 Entry and exit. Pools shall have at least two means of entry and exit located so as to serve both ends of a pool. Where areas have water depths of 24 inches (607mm) or less at the pool wall, such areas shall be considered as providing their own natural mode for entry and exit.

411.1.1 Natural entry. For other than wading pools, where areas have water depths of 24 inches (607mm) or less at the pool wall, such areas shall be considered as providing their own natural mode for entry and exit.

411.1.2 Shallow area. A means of entry and exit shall be provided in all shallow areas of all pools and shall consist of pool stairs, a ramp or a beach entry.

411.1.3 Deep area. The means of entry and exit in the deep area of pools shall consist of one of the following:

1. Steps/stairs
2. Ladders
3. Grab rails with recessed treads
4. Ramps
5. Beach entries
6. Swimouts
7. Other designs that provide the minimum utility as specified in this code.

411.1.4 Both sides of deep area. Swimming pools over 30 feet (914 cm) in width shall be provided with entries and exits on both sides of the deep area of the pool.

411.1.5 Diving envelope. Where the pool is designed for use with diving equipment, the entries and exits, pool stairs, ladders, underwater benches, special features and other accessories shall be located outside of the minimum diving water envelope as shown in Figure 322.1.

411.1.6 Treads. Treads shall have slip-resistant surfaces.

411.2 Pool stairs. The design and construction of stairs extending into the pool in either shallow or deep water, including recessed pool stairs, shall comply with Sections 411 through 411.1.

411.2.1 Tread dimensions and area. Treads shall be not less than 24 inches (607mm) at the leading edge. Treads shall have an unobstructed surface area of not less than 240 square inches (154838mm²) and an unobstructed horizontal depth of not less than 10 inches (254 mm) at the center line.

411.2.2 Risers. Risers, except for the bottom riser, shall have a uniform height of not greater than 12 inches (305 mm) measured at the center line. The bottom riser height is allowed to vary to the floor.

411.2.3 Top tread. The vertical distance from the pool coping, deck, or step surface to the uppermost tread shall be not greater than 12 inches (305 mm).

411.2.4 Bottom tread. Where stairs are located in water depths greater than 48 inches (1219mm), the lowest tread shall be not less than 48 inches (1219mm) below the deck and shall be recessed in the pool wall.

411.3 Shallow end detail for beach and sloping entries. Sloping entries used as a pool entrance shall have a max slope of 1 unit vertical in 10 units horizontal.

411.3.1 Benches and steps. Where benches are used in conjunction with sloping entries, the vertical riser distance shall not exceed 12 inches (305 mm). Where steps are used in conjunction with sloping entries the requirements of 411.2 shall apply.

411.3.2 Vertical drops. A vertical drop exceeding 12 inches (305 mm) within a sloping entry shall be provided with a handrail.

411.3.3 Surfaces. Beach and sloping entry surfaces shall be of slip-resistant materials.

411.4 Pool ladder design and construction. The design and construction of ladders shall comply with Section 322.

411.5 Underwater seats, benches, and swimouts. The design and construction of underwater seats, benches, and swimouts shall comply with Sections 411.5.1 and 411.5.2.

411.5.1 Swimouts. Swimouts, located in either the deep or shallow area of a pool, shall comply with all of the following:

1. The horizontal surface shall be not greater than 20 inches (508mm) below water line.
2. An unobstructed surface shall be provided that is equal to or greater than that required for the top tread of the pool stairs in accordance with Section 411.2
3. Where used as an entry and exit access, swimouts shall be provided with steps that comply with the pool stair requirements of Section 411.2
4. The leading edge shall be visibly set apart.

411.5.2 Underwater seats and benches. Underwater seats and benches, whether used alone or in conjunction with pool stairs, shall comply with all of the following:

1. The horizontal surface shall be not greater than 20 inches (508mm) below the water line.
2. An unobstructed surface shall be provided that is a not less than of 10 inches (254 mm) in depth and not less than 24 inches (607mm) in width.
3. Underwater seats and benches shall not be used as the required entry and exit access.
4. Where underwater seats are located in the deep area of the pool where manufactured or constructed diving equipment is installed, such seats shall be located outside of the minimum water envelope for diving equipment.
5. The leading edge shall be visually set apart.
6. The horizontal surface shall be at or below the water line.
7. A tanning ledge or sun shelf used as the required entry and exit access shall be located not greater than 12 inches below the water line.

SECTION 412 SIGNAGE

412.1 Safety signage. Safety signage advising on the danger of diving into shallow areas and on the prevention of drowning shall be provided as required by the authority that governs such pools. Safety signage shall be as shown in Figure 412.1 or similar thereto.

412.2 Sign placement. Signs shall be positioned for effective visual observation by users as required by the authority that governs such pools.

412.3 Emergency shutoff switch. Signs shall be posted that clearly indicate the location of the pump emergency shut-off switch. Such switch shall be clearly labeled as the pump emergency shutoff switch.



Actual Size:
11" x 13-3/8"
16" x 18-1/2"
18-3/8" x 24"

SAFETY SIGN
Figure 412.1

CHAPTER 5

PUBLIC SPAS AND PUBLIC EXERCISE SPAS

SECTION 501 GENERAL

501.1 Scope. This chapter shall govern the design, installation, construction and repair of public spas and exercise spas regardless of whether a fee is charged for use.

501.2 General. In addition to the requirements of this chapter, public spas and public exercise spas shall also comply with the requirements of Chapter 3.

SECTION 502 MATERIALS

502.1 Reservoirs and shells. Spa and exercise spa reservoirs shall conform to one or more of the standards listed in Table 502.1.

**TABLE 502.1
RESERVOIRS AND SHELLS**

MATERIAL	STANDARD
Dry Shotcrete	ACI 304.2, ACI 308, ACI 506.2
Wet Shotcrete	ACI 306, ACI 305, ACI 308, ACI 506.2
Poured-in-Place Concrete	ACI 318
Plastic	ANSI Z124.7
Tile	IAPMO IS-2, ASC A108/A118/A136.1
Stainless Steel (Type 316, 316L, 304, 304L)	ASTM A240
Vinyl	ASTM D1593
Fiberglass Reinforced Plastic	ANSI Z124.7

502.2 Pumps and motors. Pumps and motors shall be approved for use in spas.

SECTION 503 STRUCTURE AND DESIGN

503.1 Water depth. The maximum water depth for spas shall be 4 feet (1219 mm) measured from the design waterline except for spas that are designed for special purposes and approved by the authority having jurisdiction. The water depth for exercise spas shall not exceed 6 feet 6 inches (1981 mm) measured from the design waterline.

503.2 Multi-level seating. Where multi-level seating is provided, the maximum water depth of any seat or sitting bench shall be 28 inches (711 mm) measured from the design waterline to the lowest measurable point.

503.3 Floor slope. The slope of the floor shall not exceed 1 unit vertical in 12 units horizontal (8.3 percent slope). Where multi-level floors are provided, the change in depth shall be indicated.

SECTION 504 PUMPS AND MOTORS

504.1 Emergency shutoff switch. One emergency shutoff switch shall be provided to disconnect all power to circulation and jet system pumps and air blowers. Emergency shutoff switches shall be

accessible, located within sight of the spa and shall be located not less than 5 feet (1524 mm) but not greater than 10 feet (3048 mm) horizontally from the inside walls of the spa.

504.1.1 Alarms. Emergency shutoff switches shall be provided with an audible alarm rated at not less than 80 decibel sound pressure level and a light near the spa that will operate continuously until deactivated when the shutoff switch is operated. The following statements shall appear on a sign that is posted in a location that is visible from the spa: "ALARM INDICATES SPA PUMPS OFF. DO NOT USE SPA WHEN ALARM SOUNDS AND LIGHT IS ILLUMINATED UNTIL ADVISED OTHERWISE."

SECTION 505 RETURN AND SUCTION FITTINGS

505.1 Return and suction fittings. Return and suction fitting(s) shall be provided and arranged to facilitate a uniform circulation of water and maintain a uniform sanitizer residual throughout the entire spa or exercise spa.

505.1.1 Testing and certification. Suction fittings shall be listed and labeled to ASME A112.19.8.

505.1.2 Installation. Suction fittings shall be sized and installed in accordance with manufacturer's specifications. Spas and exercise spas shall not be used or operated if the suction outlet cover is missing, damaged, broken or loose.

505.1.3 Outlets per pump. Suction fittings shall be provided in accordance with APSP 7.

505.1.4 Submerged vacuum fittings. Submerged vacuum fittings shall be prohibited.

SECTION 506 HEATER AND TEMPERATURE REQUIREMENTS

506.1 General. This section pertains to fuel-fired and electric appliances used for heating spa or exercise spa water.

506.2 Water temperature controls. Components provided for water temperature controls shall be suitable for the intended application.

506.2.1 Water temperature regulating controls. Water temperature regulating controls shall comply with UL 873 or UL 372. A means shall be provided to check the water temperature in the spa.

506.2.2 Water temperature limiting controls. Water temperature limiting controls shall comply with UL 873 or UL 372. Water temperature at the heater return outlet shall not exceed 122°F (50°C).

SECTION 507 WATER SUPPLY

507.1 Water temperature. The temperature of the incoming make-up water shall not exceed 104°F (40°C).

SECTION 508 SANITIZING, OXIDATION EQUIPMENT AND CHEMICAL FEEDERS

508.1 Automatic controllers. Spas and hot tubs for public use shall be installed with an automatic pH and an Oxygen Reduction Potential controller listed and labeled as in compliance with NSF 50.

SECTION 509 SAFETY FEATURES

509.1 Instructions and safety signs. Instructions and safety signage shall comply with the requirements of the local jurisdiction. In the absence of local requirements, safety signs and instructions shall comply with UL 1563 or CSA C22.2 No. 218.1.

509.2 Operational signs. Operational signs shall include, but not be limited to, the following messages as required by the local jurisdiction:

1. Do not allow the use of or operate spa if the suction outlet cover is missing, damaged or loose.
2. Check spa temperature before each use. Do not enter the spa if the temperature is above 104°F (40°C).
3. Keep all breakable objects out of the spa area.
4. Spa shall not be operated during severe weather conditions.
5. Never place electrical appliances within 5 feet (1524 mm) of the spa.
6. No diving.

509.3 Depth markers. Public spas shall have permanent depth markers with numbers not less than 4 inches (102 mm) in height that are plainly and conspicuously visible from all obvious points of entry and in conformance with this section.

509.3.1 Number. There shall be a not less than two depth markers per spa, regardless of spa size or shape.

509.3.2 Spacing. Depth markers shall be spaced at not more than 25 feet (7620 mm) intervals and shall be uniformly located around the perimeter of the spa.

509.3.3 Marking. Spas and exercise spas shall have the maximum water depth clearly marked on the required surfaces and such markers shall be positioned on the deck within 18 inches (457 mm) of the design waterline. Depth markers shall be positioned to be read while standing on the deck facing the water.

509.3.4 Slip resistance. Depth markers in or on the deck surfaces shall be slip-resistant.

509.4 Clock. Public facilities shall have a clock that is visible to spa users.

CHAPTER 6

AQUATIC RECREATION FACILITIES

SECTION 601 GENERAL

601.1 Scope. This chapter covers public pools and water containment systems used for aquatic recreation. This chapter provides specifications for the design, equipment, operation, signs, installation, sanitation, new construction, and rehabilitation of public pools for aquatic play. This chapter covers Class D-1 through Class D-6 public pools whether they are provided as stand-alone attractions or in various combinations in a composite attraction.

601.2 Combinations. Where combinations of class D-1 through class D-6 pools exist within a facility, each element in the facility shall comply with the applicable code sections as if the element functioned as a part of a freestanding pool of Class D-1 through Class D-6.

601.3 General. In addition to the requirements of this chapter, aquatic recreation facilities shall also comply with the requirements of Chapter 3.

SECTION 602 FLOORS

602.1 Floor slope. In water depths of less than 5 feet (1524 mm), the floor slope shall be not greater than 1 unit vertical in 12 units horizontal except where the function of the attraction requires greater slopes in limited areas.

Exception: The slope of the floor in class D-3 pools shall not exceed 1 unit vertical in 7 units horizontal.

SECTION 603 MARKINGS AND INDICATORS

603.1 Markings. Markings areas of deep water shall comply with Sections 606.9 and 606.9.1 except where the function of the pool dictates otherwise.

603.2 Class D-2 pools. Where a Class D-2 pool has a bather-accessible depth greater than 4 1/2 feet (1372 mm), the floor shall have a distinctive marking at the 4 1/2 feet (1372 mm) water depth.

603.3 Shallow-to-deep end lifeline. Where a pool has a water depth ranging from less than 5 feet (1524 mm) to greater than 5 feet, a lifeline line shall be located 1 foot (305 mm) horizontally from the 5 foot depth location, towards the shallow end of the pool.

603.4 Nozzles. Pools having non-flush propulsion nozzles in the floor shall have a distinctive marking at location of such nozzles.

SECTION 604 CIRCULATION SYSTEMS

604.1 General. A circulation system consisting of pumps, piping, return inlets and suction outlets, filters, and other necessary equipment shall be provided for complete circulation of water with the pool.

604.2 Turnover. Circulation system equipment shall be designed to turnover 100 percent of the nominal pool water volume in the amount of time specified in Table 604.2. The system shall be designed to give

the required turnover time based on the manufacturer's recommended maximum pressure and flow of the filter in clean media condition.

**TABLE 604.2
TURNOVER TIME**

CLASS OF POOL	MAXIMUM TURNOVER TIME ^a (hours)
D-1	2
D-2 with less than 24 inches water depth	1
D-2 with 24 inches or greater water depth	2
D-3	1
D-4	2
D-5	1
D-6	1

a. Pools with a sand bottom require a 1 hour turnover time.

604.2.1 24-hour circulation required. Circulation systems shall circulate treated and filtered water for 24 hours a day.

604.2.2 Reduced circulation rate. The circulation rate shall be permitted to be reduced during periods that the pool is closed to use provided that acceptable water clarity conditions are met prior to reopening the pool for public use. At no time shall the circulation rate be zero.

604.3 Surface skimming systems. Surface skimming systems shall be in accordance with Table 604.3.

**TABLE 604.3
SURFACE SKIMMING SYSTEMS**

CLASS OF POOL	SURFACE SKIMMING SYSTEM
D-1	zero-depth trench located at static water level or other skimming systems
D-2	auto skimmer, zero depth trench or gutters
D-3	auto skimmer, zero depth trench or perimeter device
D-4	Single or multiple skimmer devices for skimming flow
D-5	Skimmers prohibited in side area
D-6	auto skimmer, zero depth trench, or gutter.

604.3.1 D-5 pool skimmers. The installation of skimmers in the side areas of D-5 pools shall be prohibited.

**SECTION 605
HANDHOLDS AND ROPES**

605.1 Handholds. Handholds shall be provided in accordance with Section 323.

Exception: Handholds shall not be provided for wave action and action rivers.

605.2 Rope and float line. A rope and float line shall be provided for all of the following situations.

1. Separation of activity areas.
2. Identification of a break in floor slope at water depths of less than 5 feet (1524 mm).
3. Identification of a water depth greater than 4.5 feet (1372 mm) in constant floor slope in Class D-2 pools.

Exception: D-1 pools or any other pool where the designer indicates that such a line is not required or that the line would constitute a hazard.

605.2.1 Location. The rope and float line shall be located 1 foot (305 mm) toward the shallow end in each location.

605.3 Cassion wall rope and float line. For Class D-1 pools, a rope and float line shall be installed to restrict bather access to the caisson wall. The location of the rope and float line shall be in accordance with the wave equipment manufacturer’s instructions.

605.4 Fastening. Rope and float lines shall be securely fastened to wall anchors of corrosion-resistant materials. Wall anchors shall be of the recessed type and shall not have projections that will constitute a hazard when the rope and float line is removed.

605.5 Size. Rope and float lines shall be not less than 5/8 inch (16 mm) diameter and shall be made of polypropylene material.

**SECTION 606
DEPTHS**

606.1 Class D-6 depth. The captured or standing water depth in Class D-6 pools shall be not more than 12 inches.

606.2 Spray Pools. The water depths in spray pools shall be not more than 6 inches.

**SECTION 607
BARRIERS**

607.1 Barriers. Multiple aquatic vessels within a single complex shall be permitted without barriers where a barrier separates the single complex from the surrounding property in accordance with Section 305.

**SECTION 608
NUMBER OF OCCUPANTS**

608.1 Occupant load. The occupant load for the aquatic vessels in the facility shall be calculated in accordance with Table 608.1. The occupant load shall be the combined total of the number of users based on the vessel water surface area and the deck area surrounding the vessel. The deck area occupant load shall be based on the occupant load calculated where a deck is provided or based on an assumed 4 foot wide deck surrounding the entire perimeter of the vessel, whichever is greater.

**TABLE 608.1
OCCUPANT LOAD**

	Shallow or wading areas	Deep area (not including the diving area)	Diving area (per each diving board)	Deck area
Vessel water surface area	8 sq. ft per user	10 sq. ft. per user	300 sq. ft. per user	_____
Deck area	-----	-----	-----	1 user per 50 sq. ft.

608.2 Facility capacity. For multiple aquatic vessels in a single aquatic recreation facility, the total facility occupant capacity shall not be limited by the number of occupants calculated in accordance with Section 608.1.

**SECTION 609
TOILET ROOMS AND BATHROOMS**

609.1 General. Toilet rooms and bathrooms shall be in accordance with the *International Plumbing Code* and the *International Building Code* based on the occupant load calculated in accordance with Section 609. One deck shower shall be provided for each 200 bathers or fraction thereof with not less than of one for each pool.

**SECTION 610
SPECIAL FEATURES**

610.1 Locations. Entry and exit locations shall be in accordance with Table 610.1. The primary means of entry and exit shall consist of ramps, a beach entries, pool stairs, or ladders.

**TABLE 610.1
ENTRY AND EXIT LOCATIONS**

CLASS OF POOL	ENTRY AND EXIT LOCATIONS
D-1	Entry at beach end only. Exit at beach end, sides or end wall
D-2	Entry and exit determined by the pool designer.
D-3	Entry prohibited from deck areas. Exit by ladders, steps or ramps as determined by pool designer.
D-4	Entry and exit determined by the pool designer.
D-5	Entry and exit determined by the pool designer.
D-6	Entry and exit determined by the pool designer.

610.2 Secondary entry exit means. Where secondary means of entry and exit are provided, they shall consist of one of the following:

1. steps
2. stairs
3. ladders with grab rails
4. recessed treads
5. ramps
6. beach entries
7. swimouts
8. designs that provide the minimum utility as specified in this standard.

610.3 Provisions for diving. Where diving facilities are part of the attraction or pool complex, entries, exits, pool stairs, ladders, underwater benches, special features, and other accessories shall be located outside of the minimum diving water envelope in accordance with Figure 322.2.

610.4 Beach entry, zero-depth entry, and sloping entries. The shallow end for beach entries and sloping entries shall be in accordance with Sections 611.5.1 through 611.5.6.6.

610.4.1 Maximum entry slope. The slope of sloping entries used as a pool entry shall not exceed 1 unit vertical in 12 units horizontal.

610.4.2 Benches. Where benches are used in conjunction with sloping entries, the vertical riser height shall not exceed 12 inches (305 mm).

610.4.3 Steps. Where steps are used in conjunction with sloping entries, all of the requirements of Section 605.5.6 shall apply.

610.4.4 Slip-resistant surfaces. Beach and sloping entry walking surfaces at water depths up to 18 inches (457 mm) shall be slip-resistant.

610.5 Pool steps. The design and construction of steps for stairs into the shallow end and recessed pool stairs shall be in accordance with Sections 611.5.5.1 through 611.5.5.6.

610.5.1 Uniform height of 9 inches. Except for the bottom riser, risers at the centerline shall have a maximum uniform height of 9 inches (229 mm). The bottom riser height shall be permitted to vary from the other risers.

610.5.2 Distance from coping or deck. The vertical distance from the pool coping, deck, or step surface to the uppermost tread shall be not greater than 9 inches (229 mm).

610.5.3 Color to mark leading edge. The leading edge of all steps shall be distinguished by a color contrasting with the color of the steps and the pool floor.

610.5.4 Stairs in water depths over 48 inches. Stairs that are located in water depth greater than 48 inches (1219 mm) shall have the lowest tread located below the deck at a distance of not less than 48 inches (1219 mm) below the deck.

610.5.5 Tread horizontal depth. Treads shall have a unobstructed horizontal depth of not less than 11 inches (279 mm).

610.5.6 Tread surface area. Treads shall have an unobstructed surface area of not less than 240 square inches (154838 mm²).

610.6 Swimouts. Swimouts shall be located completely outside of the water current or wave action of the aquatic vessel and can be located in shallow or deep areas of water.

610.6.1 Surface area. An unobstructed surface equal to or greater than that required for the top tread of the pool stairs shall be provided. (See Section 611.5.6.6)

610.6.2 Step required. Where a swimout is used as an entry and exit access point, it shall be provided with a step that meets the pool stair requirements (See Section 611.5.6).

610.6.3 Maximum depth. The horizontal surface of a swimout shall be not greater than 20 inches (508 mm) below the water line.

610.6.4 Color marking. The leading edge of a swimout shall be visually set apart by a stripe having a width of not less than 3/4 inch (19 mm) and not greater than 2 inches (51 mm). The stripe shall be of a contrasting color to the adjacent surfaces.

610.7 Underwater seats and benches. Under water seats and benches shall comply with this section.

610.7.1 Prohibited location. Underwater seats shall not be located in the diving water envelope.

610.7.2 Surface dimensions. Underwater seats shall have an unobstructed surface dimension of not less than 10 inches (254 mm) measured front to back and not less than 24 inches (610 mm) in width.

610.7.3 Not an entry or exit. Underwater seats and benches shall not be used as an entry or exit for a pool but can be located in shallow or deep areas of water.

610.7.4 Depth. The horizontal surface of seats and benches shall be not greater than 20 inches (508 mm) below the water line.

610.7.5 Color marking. The leading edge of a seats and benches shall be visually set apart by a stripe having a width not less than ¾ inch (19 mm) and not greater than 2 inches (51 mm). The stripe shall be of a contrasting color to the adjacent surfaces.

610.7.6 Slip resistant. The top surface of seats and benches shall be slip-resistant.

610.8 Objects permitted. The design, construction, and operation of decorative objects and structures intended for climbing, walking, and hanging on by a bather are not covered by this code.

610.8.1 Floating devices. Floating devices not intended to be mobile shall be anchored in a manner to restrict movement to the range established by the designer. The anchoring of such floating devices shall be configured to minimize the possibility of entrapment of bathers, bodies, hair, limbs, and appendages should they come in contact with any element of the floating device or its anchors.

SECTION 611 SIGNAGE

611.1 Posting of signs. Signs stating rules, instructions, and warnings shall be posted. Signs for suction entrapment warning in accordance with Section 310 shall be posted. Signs shall be placed so that they squarely face approaching traffic. The center of the message panel shall be located not less than 66 inches (1676 mm) above the walking surface.

611.2 Prohibited mounting. Signs shall not be mounted on fences and gates alongside of guest walkways and staircases.

611.3 Message delivery. Messages delivered on signs shall comply with all of the following:

1. Messages shall be pertinent to the activity being performed or to be performed.
2. Messages shall be specific by providing details about the activity.
3. Messages shall be short and concise.
4. Messages shall be direct without humor or embellishments.

611.4 Text font and size. The message text shall be in a clear, bold font such as Arial. The character height shall be proportional to 1 inch (25 mm) for 10 feet (2048) of intended viewing distance but not less than 1 inch (25 mm).

611.5 Distinct sign classes. Facility signs shall be categorized into four sign classes in accordance with Sections 611.5.1 through 611.5.4.

611.5.1 General information. General information signs shall be posted facility-wide and shall not be attraction specific.

611.5.2 Directional signs. Directional signs shall identify the location of services and attractions in the park and shall include directional arrows. Directional signs shall be posted at various crossroads in the facility.

611.5.3 Rules signs. Rules signs shall inform the guests of the qualifications that they must meet to allow them to participate on a specific ride or attraction. Rules shall include but are not limited to limits for weight and height, proper attire and, ride and ride vehicle stipulations. Rules signs shall be located at a point where the guests make the initial commitment to participate on the ride.

611.5.4 Instructional signs. Instructional signs shall inform guests of specific instructions for the use of the ride. Instructions shall include but are not limited to riding posture, prohibited activity, and user exit requirements at the ride termination. Instructional signs shall be located along the queue approaching the ride dispatch area.

611.6 Materials. Sign panels shall be durable for the weather conditions and shall be resistant to damage from guests. The message surface shall be clean and smooth and shall readily accept paint or pre-cut lettering adhesives.

611.7 Shape and size consistency. The panel shape and size for each class of signs shall be the same. Where the total message to be indicated is larger than what can be placed upon one sign, multiple signs of the same size shall be used to display the message.

611.8 Pictograms. Pictograms shall always be accompanied by text indicating the same message. Pictograms shall be designed to illustrate one clear and specific meaning to all individuals.

611.9 Theming or artwork. Theming or artwork applied to signs shall not invade the message panel. Signs shall have a distinct border.

611.10 Shallow water. Safety signs shall be in accordance with Section 412.

611.11 Cold water. Where a pool could have a water temperature below 70° F (21° C), a cold water warning sign shall be posted at the point of entry to the pool or at the attraction using such water.

CHAPTER 7

ONGROUND STORABLE RESIDENTIAL SWIMMING POOLS

SECTION 701 GENERAL

701.1 Scope. This chapter describes certain criteria for the design, manufacturing, and testing of onground storable pools intended for residential use. This includes portable pools with flexible or non-rigid side walls that achieve their structural integrity by means of uniform shape, support frame or a combination thereof, and that can be disassembled for storage or relocation.

701.2 General. In addition to the requirements of this chapter, onground storable residential swimming pools shall also comply with the requirements of Chapter 3.

701.3 Floor slopes. Floor slopes shall be uniform and in accordance with Sections 701.3.1 through 701.3.4

701.3.1 Shallow end. The slope of the floor from the shallow end wall towards the deep area shall not exceed 1 unit vertical in 7 units horizontal to the point of the first slope change.

701.3.2 Transition. The slope of the floor from the point of the first slope change towards the deepest point shall not exceed 1 unit vertical in 3 units horizontal.

701.3.3 Adjacent. The slope adjacent to the shallow area shall not exceed 1 unit vertical in 3 units horizontal and the slope adjacent to the side walls shall not exceed 1 unit vertical in 1 unit horizontal.

701.3.4 Change point. The point of the first slope change shall be defined as the point at which the shallow area slope exceeds 1 unit vertical in 7 units horizontal and is not less than 6 feet (1889 mm) from the shallow end wall of the pool.

701.4 Identification. The manufacturer's name and the liner identification number shall be affixed to the onground storable residential pool vinyl liner.

701.5 Installation. Ongoing storable pools shall be installed in accordance with the manufacturer's instructions.

SECTION 702 LADDERS AND STAIRS

702.1 Ladders and stairs. Pools shall have a means of entry and exit consisting of not less than one ladder or a ladder and staircase combination.

702.2 Type A and Type B ladders. Type A, double access, and Type B, limited access, A-frame ladders shall comply with Sections 702.2.1 through 702.2.7. See Figure 702.2.

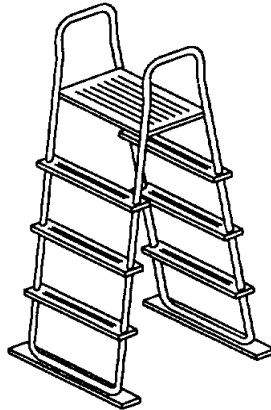

**FIGURE 702.2
TYPICAL A-FRAME LADDER
TYPES A AND B**

702.2.1 Barrier required. Ladders in the pool shall have a physical barrier to prevent children from swimming through the riser openings or behind the ladder.

702.2.2 Platform. Where an A-frame ladder has a platform between the handrails, the platform shall have a width of not less than 12 inches (305 mm) and length of not less than 12 inches (305 mm). The platform shall be at or above the highest ladder tread. The walking surface of the platform shall be slip-resistant.

702.2.3 Handrails/handholds. A-frame ladders shall have two handrails or handholds that serve all treads. The height of the handrails or handholds shall be not less than 20 inches (508 mm) above the platform or uppermost tread, whichever is higher.

702.2.4 Diameter. The outside diameter of handrails/handholds shall be not less than 1 ¼ inches (32 mm) and not greater than 2 inches (50 mm).

702.2.5 Clear distance. The clear distance between ladder handrails shall be not less than space 12 inches (305 mm).

702.2.6 Treads. Ladder treads shall have a horizontal uniform depth of not less than 2 inches (51 mm).

702.2.7 Riser height. All risers shall be of a uniform height of not less than 7 inches (178 mm) and not greater than 12-inches (305 mm). The vertical distance from the platform or top of the pool structure to the uppermost tread shall be uniform with other riser heights.

Exception: The height of the bottom riser shall be permitted to vary from the other risers.

702.3 Type C staircase ladders (ground to deck). Type C staircase ladders shall comply with Sections 702.3.1 through 702.3.6. See Figure 702.3.

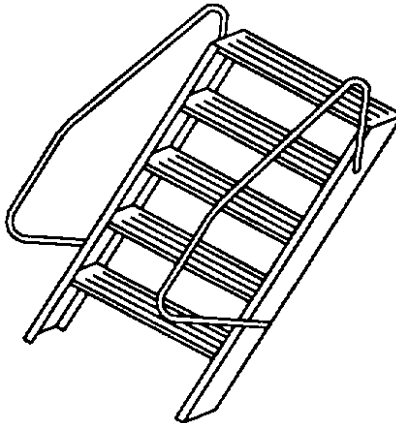

**FIGURE 702.3
TYPICAL IN-POOL STAIRCASE LADDER
TYPE C**

702.3.1 Handrails or handholds. Staircase ladders shall have not less than two handrails or handholds that serve all treads. The height of the handrails or handholds shall be not less than 20 inches (508 mm) above the platform or uppermost tread, whichever is higher.

702.3.2 Diameter. The outside diameter of handrails and handholds shall be not less than 1 ¼ inches (32 mm) and not greater than 2 inches (50 mm).

702.3.3 Treads. Ladder treads shall have a horizontal uniform depth of not less than 4 inches (102 mm).

702.3.4 Riser height. Risers shall be of a uniform height not less than 7 inches (178 mm) and not greater than 12-inches (305 mm). The vertical distance from the platform or top of the pool structure to the uppermost tread shall be uniform with other riser heights.

Exception: The height of the bottom riser shall be permitted to vary from the other risers.

702.3.5 Top step. The top step of a staircase ladder shall be flush with the deck or between 7 inches (178 mm) to 12 inches (305 mm) below the deck level.

702.3.6 Width. Steps shall have a minimum unobstructed width of 19 inches (483 mm) between the side rails.

702.4 Type D in-pool ladders. Type D in-pool ladders shall be in accordance with Sections 702.4.1 through 702.4.6. See Figure 702.4.

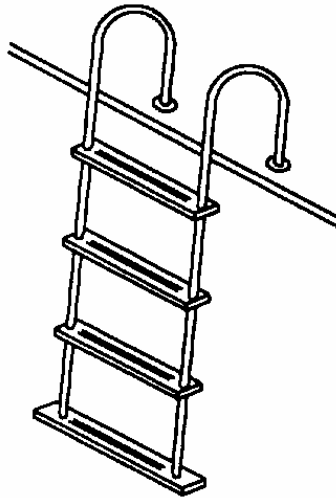

**FIGURE 702.4
TYPICAL IN-POOL LADDER
TYPE D**

702.4.1 Clearance. There shall be a clearance of not less than 3 inches (76 mm) and not greater than 6 inches (152 mm) between the pool wall and the ladder.

702.4.2 Handrails or handholds. Ladders shall be equipped with two handrails or handholds that extend above the platform or deck not less than 20 inches (508 mm).

702.4.3 Clear distance. The clear distance between ladder handrails shall be not less than 12 inches (305 mm).

702.4.4 Diameter. The outside diameter of handrails and handholds shall be not less than 1 inch (25 mm) and not greater than 2 inches (50 mm).

702.4.5 Riser height. Risers shall be a uniform height not less than 7 inches (178 mm) and not greater than 12-inches (305 mm).

Exception: The height of the bottom riser shall be permitted to vary from the other risers.

702.4.5 Top tread. The vertical distance from the pool coping, deck, or step surface to the uppermost tread shall be not less than 7 inches (178 mm) and not greater than 12 inches (305 mm) and uniform with other riser heights.

702.4.6 Tread depth. Ladder treads shall have a horizontal uniform depth of not less than 2 inches (51 mm).

702.5 Type E, protruding in-pool stairs. Type E protruding in-pool stairs shall be in accordance with Sections 702.5.1 through 702.5.7. See Figure 702.5.

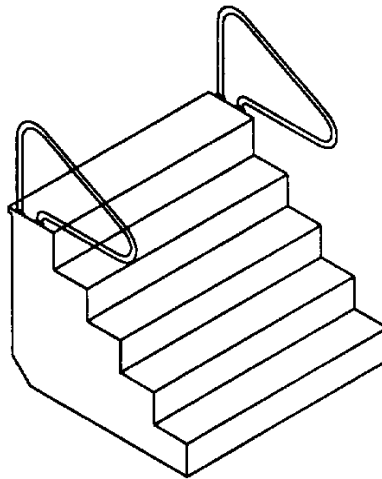

**FIGURE 702.5
TYPICAL IN-POOL STAIRCASE
TYPES E and F**

702.5.1 Barrier required. Ladders in the pool shall have a physical barrier to prevent children from swimming through the riser openings or behind the ladder.

702.5.2 Handrail or handhold. In-pool stairs shall be equipped with not less than one handrail or handhold that serves all treads with a height of not less than 20 inches (508 mm) above the platform or uppermost tread, whichever is higher.

702.5.3 Removable handrails. Where handrails are removable, they shall be installed that they cannot be removed without the use of tools.

702.5.4 Leading edge distance. The leading edge of handrails shall be 18 inches (457 mm) \pm 3 inches (\pm 76 mm), horizontally from the vertical plane of the bottom riser.

702.5.5 Diameter. The outside diameter of handrails or handholds shall be not less than 1 1/4 inches (32 mm) and not greater than 2 inches (50 mm).

702.5.6 Tread width and depth. Treads shall have an unobstructed horizontal depth of not less than 10 inches (254 mm) at all points and an unobstructed surface area of not less than 240 square inches (154838 mm²).

702.5.7 Uniform riser height. Risers shall have a uniform height of not less than 7 inches (178 mm) and not greater than 12 inches (305 mm).

Exceptions:

1. The height of the bottom riser can vary from the other risers.
2. The vertical distance from the pool coping, deck, or step surface to the uppermost tread shall be not less than 7 inches (178 mm), not greater than 12 inches (305 mm) and uniform with other riser heights.

702.6 Type F recessed in-pool stairs. Type F recessed in-pool stairs shall be in accordance with Sections 702.6.1 through 702.6.7. See Figure 702.5.

702.6.1 Barrier required. Ladders in the pool shall have a physical barrier to prevent children from swimming through the riser openings or behind the ladder.

702.6.2 Handrail or handhold. In-pool stairs shall be equipped with not less than one handrail or handhold that serves all treads with a height of not less than 20 inches (508 mm) above the platform or uppermost tread, whichever is higher.

702.6.3 Removable handrails. Where handrails are removable, they shall be installed so that they cannot be removed without the use of tools.

702.6.4 Leading edge distance. The leading edge of handrails shall be 18 inches (457 mm) \pm 3 inches (\pm 76 mm), horizontally from the vertical plane of the bottom riser.

702.6.5 Diameter. The outside diameter of handrails and handholds shall be not less than 1 ¼ inch (32 mm) and not greater than 2 inches (48 mm).

702.6.6 Tread width and depth. Treads shall have an unobstructed horizontal depth of not less than 10 inches (254 mm) at all points and an unobstructed surface area of not less than 240 square inches (154838 mm²).

702.6.7 Uniform riser height. All risers shall have a uniform height of not less than 7 inches (178 mm) and not greater than 12 inches (305 mm).

Exceptions:

1. The height of the bottom riser can vary from the other risers.
2. The vertical distance from the pool coping, deck, or step surface to the uppermost tread shall be not less than 7 inches (178 mm), not greater than 12 inches (305 mm) and uniform with other riser heights.

**SECTION 703
DECKS**

703.1 General. Decks provided by the pool manufacturer shall be installed accordance with the manufacturer's instructions. Decks fabricated on-site shall be in accordance with the *International Residential Code*.

703.2 Cantilevered. Cantilevered decks shall not exceed the height of the pool.

703.3 No gaps. Decks that are installed flush with the top rail of the pool shall have all gap openings between the deck and top rails closed-off or capped.

703.4 Extension over pool. Where a deck extends inside the top rail of the pool, it shall extend not more than 3 inches (76 mm) beyond the inside of the top rail of the pool in accordance with Figure 703.4 and shall have a smooth finish.

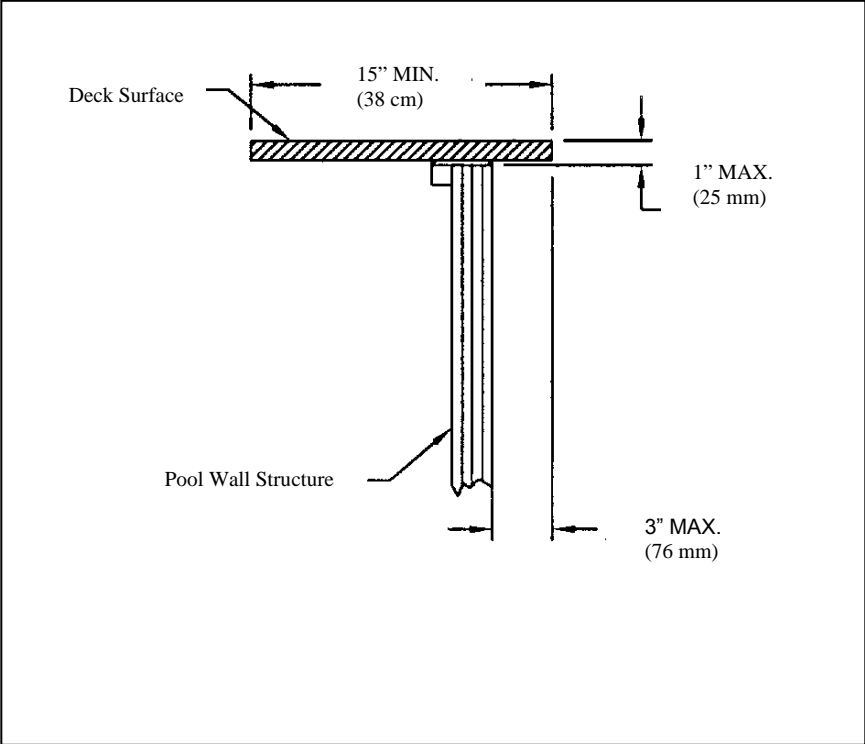
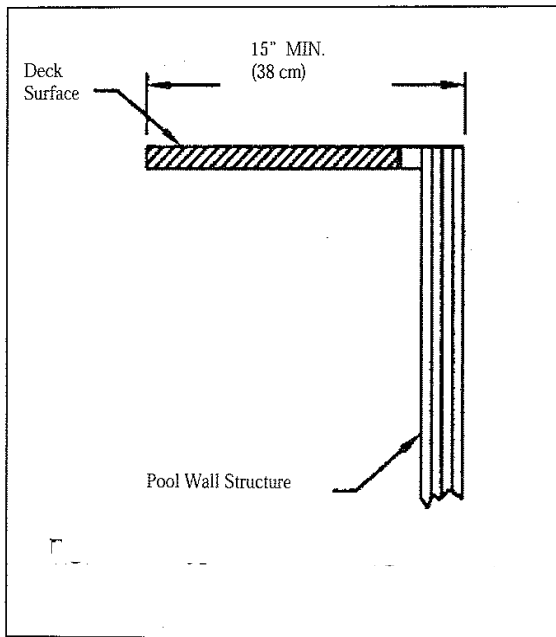

FIGURE 703.4
TYPICAL CANTILEVER DECK SUPPORT

703.5 Slip resistant. The deck walking surface shall be slip-resistant.

703.6 Walk-around decks. Walk-around decks shall have a level walking surface of not less than 15 inches (381 mm) in width, as measured from the inside edge of the pool top rail to the outside of the pool walk-around. See Figure 703.6.



**FIGURE 703.6
WALK-AROUND DECK WIDTH**

SECTION 704 CIRCULATION SYSTEM

704.1 Draining the system. In climates subject to freezing, circulation system equipment shall be designed and fabricated to drain the pool water from the equipment and exposed piping, by removal of drain plugs and manipulating valves or by other methods in accordance with manufacturer's instructions

704.2 Turnover. Where circulation equipment is required by the manufacturer, the equipment shall be sized to provide a turnover of the pool water at least once every 12 hours. The system shall be designed to provide the required turnover rate based on the manufacturer's specified maximum flow rate of the filter, with a clean media condition of the filter.

CHAPTER 8

PERMANENT INGROUND RESIDENTIAL SWIMMING POOLS

SECTION 801 GENERAL

801.1 Scope. The provisions of this chapter shall govern permanent inground residential swimming pools that are installed for residential use. This chapter covers new construction, modification or repair and residential aquatic vessels.

801.2 General. Permanent inground residential pools shall also comply with the requirements of Chapter 3.

SECTION 802 DESIGN

802.1 Materials of components and accessories. The materials of components and accessories used for permanent inground residential swimming pools shall be suitable for the environment in which they are installed. The materials shall be capable of fulfilling the design, installation and the intended use requirements in the *International Residential Code*.

802.2 Structural design. The structural design and materials shall be in accordance with the *International Residential Code*.

SECTION 803 CONSTRUCTION TOLERANCES

803.1 Construction tolerances. The construction tolerance for dimensions for the overall length, width and depth of the pool shall be ± 3 inches (76 mm). The construction tolerance for all other dimensions shall be ± 2 inches (51 mm), unless otherwise specified by the design engineer.

SECTION 804 DIVING WATER ENVELOPES

804.1 General. The minimum diving water envelopes shall be in accordance with Table 804.1 and Figure 804.1. Negative construction tolerances shall not be applied to the dimensions of the minimum diving water envelopes given in Table 804.1.

804.2 Label. Pools designed for diving shall have a label installed that indicates the type of pool with respect to the minimum diving water envelopes of Table 804.1. The label shall have a durability that complies with ASTM G154, duty cycle 1. The label shall be permanently affixed to the pool structure, at or above the design water line at the location where diving equipment will be located.

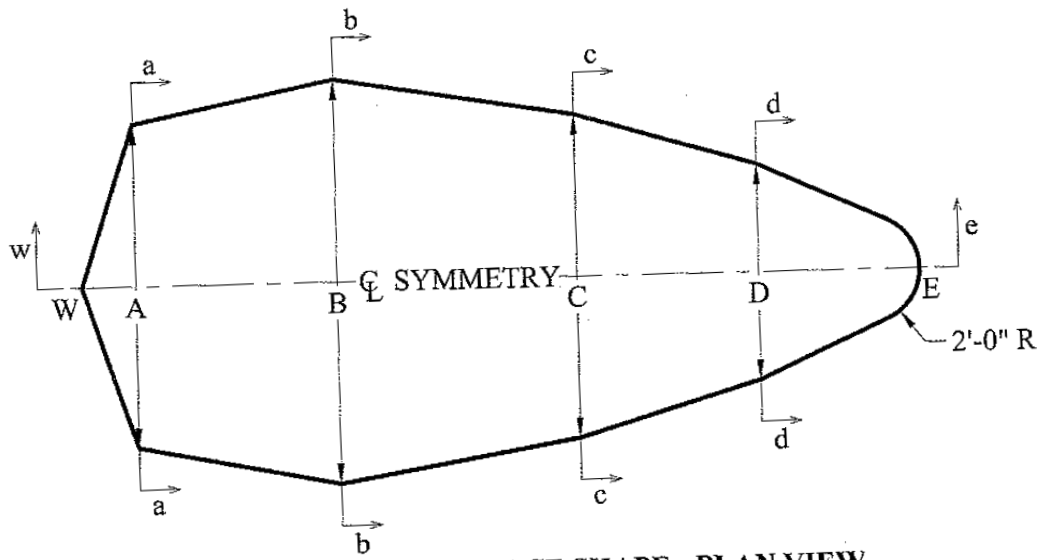

MINIMUM WATER SURFACE SHAPE - PLAN VIEW

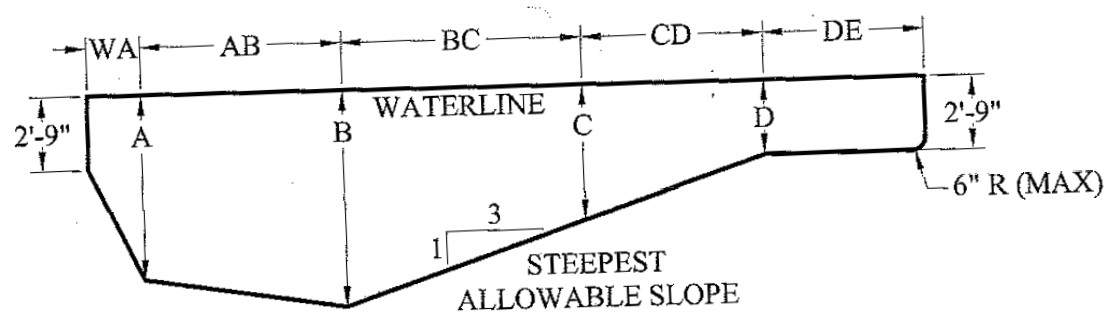

MINIMUM WATER DEPTHS - SECTION w-e

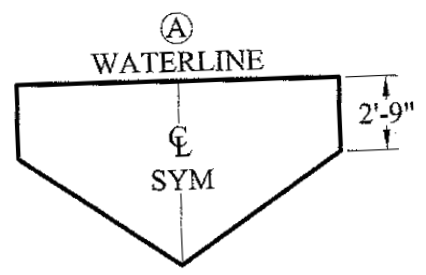

SECTION a-a

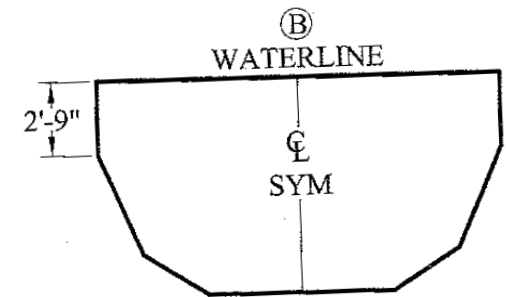

SECTION b-b

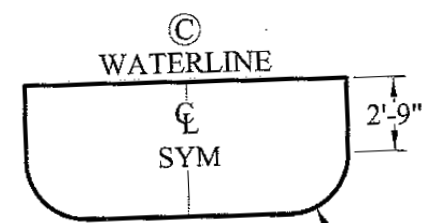

SECTION c-c

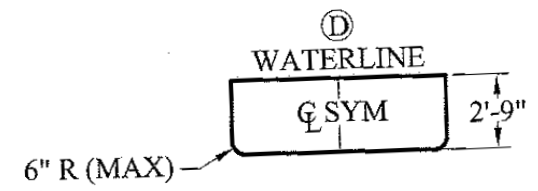

SECTION d-d

**FIGURE 804.1
MINIMUM WATER ENVELOPE**

**TABLE 804.1
MINIMUM DIVING WATER ENVELOPE FOR
SWIMMING POOLS DESIGNATED TYPES I-V^b**

POOL TYPE	MINIMUM DEPTHS AT POINT feet-inches				MINIMUM WIDTHS AT POINT feet-inches				MINIMUM LENGTHS BETWEEN POINTS feet-inches					
	A	B	C	D	A	B	C	D	WA	AB	BC	CD	DE	WE
I	6-0	7-6	5-0	2-9	10-0	12-0	10-0	8-0	1-6	7-0	7-6	^a	6-0	28-9
II	6-0	7-6	5-0	2-9	12-0	15-0	12-0	8-0	1-6	7-0	7-6	^a	6-0	28-9
III	6-10	8-0	5-0	2-9	12-0	15-0	12-0	8-0	2-0	7-6	9-0	^a	6-0	31-3
IV	7-8	8-0	5-0	2-9	15-0	18-0	15-0	9-0	2-6	8-0	10-6	^a	6-0	31-3
V	8-6	9-0	5-0	2-9	15-0	18-0	15-0	9-0	3-0	9-0	12-0	^a	6-0	36-9

a. The minimum length between points C and D varies based upon water depth at point D and the floor slope between points C and D.
b. See Figure 804.1 for location of points.

SECTION 805 WALLS

805.1 General. Walls in the shallow area and deep area of the pool shall have a wall-to-floor transition point that is not less than 33 inches (838 mm) below the design waterline. Above the transition point, the walls shall be within 11 degrees of vertical.

SECTION 806 OFFSET LEDGES

806.1 Maximum width. Offset ledges shall be not greater than 8 inches (203 mm) in width.

806.2 Reduced width required. Where an offset ledge is located less than 42 inches (1067 mm) below the design waterline, the width of such ledge shall be proportionately less than 8 inches (203 mm) in width so as to fall within 11 degrees of vertical as measured from the top of the design waterline.

SECTION 807 POOL FLOORS

807.1 Floor slopes. Floor slopes shall be in accordance with Sections 807.1.1 through 807.1.3.

807.1.1 Shallow end. The slope of the floor from the beginning of the shallow end to the deep area floor slope transition point, indicated in Figure 804.1 as point E to point D, shall not exceed 1 unit vertical in 7 units horizontal.

807.1.2 Shallow to deep transition. The shallow to deep area floor slope transition point, indicated in Figure 804.1 as point D, shall occur at a depth not less than 33 inches (838 mm) below the design waterline and at a point not less than 6 feet (1829 mm) from the beginning of the shallow end, indicated in Figure 804.1 as point E, except as specified in Section 809.7.

807.1.3 Deep end. The slope of the floor in the deep end, indicated in Figure 804.1 as point B to point D, shall not exceed a slope of 1 unit vertical in 3 units horizontal.

807.2 Shallow end water depths. The design water depth as measured at the shallowest point in the shallow area shall be not less than 33 inches (838 mm) and not greater than 4 feet (1219 mm). Shallow areas designed in accordance with Section 810.6 shall be exempt from the minimum depth requirement.

SECTION 808 DIVING EQUIPMENT

808.1 Manufactured and fabricated diving equipment. Manufactured and fabricated diving equipment shall be in accordance with this section. Manufactured and fabricated diving equipment and appurtenances shall not be installed on a Type O pool.

808.2 Manufactured diving equipment. Manufactured diving equipment shall be designed for swimming pool use.

808.3 Installation. Where manufactured diving equipment is installed, the installation shall be located in the deep area of the pool so as to provide the minimum dimensions as shown in Table 804.1 and shall be installed in accordance with manufacturer's instructions.

808.4 Labeling. Manufactured diving equipment shall have a permanently affixed label indicating the manufacturer's name and address, the date of manufacture, the minimum diving envelope and the maximum weight limitation.

808.5 Slip-resistant. Diving equipment shall have slip-resistant walking surfaces.

808.6 Point A. For the application of Table 804.1, Point A shall be the point from which all dimensions of width, length and depth are established for the minimum diving water envelope. If the tip of the diving board or diving platform is located at a distance of WA or greater from the deep end wall and the water depth at that location is equal to or greater than the water depth requirement at Point A, then the point on the water surface directly below the center of the tip of the diving board or diving platform shall be identified as Point A.

808.7 Location of pool features in a diving pool. Where a pool is designed for use with diving equipment, the location of steps, pool stairs, ladders, underwater benches, special features and other accessory items shall be outside of the minimum diving water envelope as indicated in Figure 322.2.

808.8 Stationary diving platforms and diving rocks. Stationary diving platforms and diving rocks built on-site shall be permitted to be flush with the wall and shall be located in the diving area of the pool. Point A shall be in front of the wall at the platform or diving rock centerline.

808.9 Location. Manufactured or fabricated diving equipment shall be located directly above Point A as defined by Section 808.6.

808.10 Elevation. The maximum elevation of a diving board above the design waterline shall be in accordance with the manufacturer's instructions.

808.11 Minimum water envelope. Manufactured diving equipment installation and use instructions shall be provided by the diving equipment manufacturer and shall specify the minimum water dimensions required for each diving board and diving stand combination. The board manufacturer shall indicate the water envelopes type by dimensionally relating their products to Point A on the water envelopes as shown in Figure 804.1 and Table 804.1. The board manufacturer shall specify which boards fit on the design pool geometry types as indicated in Table 804.1.

808.12 Platform height above waterline. The height of a stationary diving platform or a diving rock above the design waterline shall not exceed the dimensions in Table 808.12.

**TABLE 808.12
DIVING PLATFORM OR APPURTENANCE
HEIGHT ABOVE DESIGN WATERLINE**

POOL TYPE	HEIGHT inches
I	42
II	42
III	50
IV	60
V	69

1 inch = 25.4 mm

808.13 Manufactured diving equipment height above waterline. The diving equipment manufacturer shall specify the minimum headroom required above the board tip.

SECTION 809 SPECIAL FEATURES

809.1 Slides. Slides shall be installed in accordance with manufacturer’s instructions.

809.2 Entry and exit. Pools shall have a means of entry and exit in the shallow area if the design water depth exceeds 24 inches (610 mm) at the shallowest point. Entries and exits shall consist of one or a combination of the following: steps, stairs, ladders, treads, ramps, beach entries, underwater seats, benches, swimouts, mechanical lifts and other *approved* designs. The means of entry and exit shall be located on the shallow side of the first slope change. Pools having more than one shallow area, including but not limited to center deep, play or sports pools, shall use the same type of entry and exit in all shallow areas. Ladders shall not be installed in a shallow area of a pool.

809.3 Secondary entries and exits. Where water depth in the deep area of a pool exceeds 5 feet (1524 mm), a means of entry and exit shall be provided in the deep area of the pool.

809.4 Over 30 feet width. Pools over 30 feet (9144 mm) in width at the deep area shall have an entry and exit on both sides of the deep area of the pool.

809.5 Pool stairs. The design and construction of stairs into the shallow end and recessed pool stairs shall conform to Sections 810.5.1 through 810.5.4.

809.5.1 Tread dimension and area. Treads shall have a minimum unobstructed horizontal depth of 10 inches (254 mm) and a minimum unobstructed surface area of 240 square inches (154838 mm²).

809.5.2 Bottom riser. On shallow end stairs, the bottom riser height is allowed to vary to the floor. The bottom riser must not exceed 12 inches (305 mm) to the floor for the width of the walking surface.

809.5.3 Riser height. Risers at the centerline shall have a uniform height not greater than 12 inches (305 mm), except the top riser, which shall be permitted vary in height, but shall not exceed 12 inches (305 mm).

809.5.4 Additional Steps. In design water depths exceeding 48 inches (1219 mm), no additional steps shall be required.

809.6 Beach and sloping entries. The slope of beach and sloping entries used as a pool entrance shall not exceed 1 unit vertical in 7 units horizontal.

809.7 Steps and sloping entries. Where steps and benches are used in conjunction with sloping entries, the vertical riser distance shall not exceed 12 inches (305 mm). For steps used in conjunction with sloping entries, the requirements of Section 809.6 shall apply.

809.8 Architectural features. Surfaces of architectural features shall not be required to comply with the 1 unit vertical in 7 units horizontal slope limitation.

809.9 Maximum Depth. The horizontal surface underwater seats, benches and swimouts shall be not greater than 20 inches (508 mm) below the design waterline.

SECTION 810 CIRCULATION SYSTEMS

810.1 Turnover rate. The circulation system equipment shall be sized to provide a turnover of the pool water not less than once every twelve hours. The system shall be designed to provide the required turnover rate based on the manufacturer's specified maximum flow rate of the filter, with a clean media condition of the filter.

810.2 Pressure test. Circulation system piping, other than that integrally included in the manufacture of the pool, shall be subject to an induced static hydraulic pressure test (sealed system) at 30 psi (207 kPa) for 30 minutes.

810.3 Strainer required. Pressure filter systems shall be provided with a strainer located between the pool and the circulation pump.

SECTION 811 SAFETY FEATURES

811.1 Rope and float. In pools where the point of first slope break occurs, a rope and float assembly shall be installed across the width of the pool. The rope assembly shall be located not less than 1 foot (305 mm) and not greater than 2 feet (610 mm) towards the shallow side of the slope break. Rope anchoring devices shall be permanently attached to the pool wall, coping or deck. Rope ends shall attach to the rope anchor devices so that the rope ends can be disconnected from the rope anchor device.

CHAPTER 9

PERMANENT RESIDENTIAL SPAS AND PERMANENT RESIDENTIAL EXERCISE SPAS

SECTION 901 GENERAL

901.1 Scope. This chapter shall govern the design, installation, construction and repair of permanently installed residential spas and exercise spas intended for residential use.

901.2 General. Permanent residential spas and permanent residential exercise spas shall comply with Chapter 5 except that Sections 504.1, 504.1.1 and 508.1 and 509 shall not apply. In addition, such spas shall also comply with the requirements of Chapter 3.

SECTION 902 SAFETY FEATURES

902.1 Instructions and safety signs. Instructions and safety signage shall comply with manufacturer's recommendation and the requirements of the local jurisdiction.

CHAPTER 10

PORTABLE RESIDENTIAL SPAS AND PORTABLE RESIDENTIAL EXERCISE SPAS

SECTION 1001 GENERAL

1001.1 Scope. This chapter shall govern the installation, alternation and repair of portable residential spas and portable exercise spas intended for residential use.

1001.2 General. In addition to the requirements of this chapter, portable residential spas and portable residential exercise spas shall also comply with the requirements of Chapter 3.

1001.3 Listing. *Equipment* and appliances shall be installed as required by the terms of their approval, in accordance with the conditions of the listing, the manufacturer's installation instructions and this code. Manufacturer's installation instructions shall be available on the job site at the time of inspection.

1001.3 Certification. Factory-built portable spas and portable exercise spas installed in residential applications shall be listed and labeled in compliance with UL 1563 or CSA C22.2 No. 218.1.

1001.5 Installation. Spa equipment shall be supported to prevent damage from misalignment and settling in accordance with manufacturer's instructions.

1001.6 Suction fitting covers. Suction fitting covers shall be installed prior to final approval.

1001.6.1 Access. Electrical components that require placement or servicing shall be provided with access.

1001.7 Instructions and safety signs. Instructions and safety signage shall comply with UL 1563 or CSA C22.2 No. 218.1, manufacturer's recommendations, and the requirements of the local jurisdiction.

CHAPTER 11

REFERENCED STANDARDS

This chapter lists the standards that are referenced in various sections of this document. The standards are listed herein by the promulgating agency of the standard, the standard identification, the effective date and title, and the section or sections of this document that reference the standard. The application of the referenced standards shall be as specified in Section 102.7.

Standard reference number	Title	Referenced in code section number
304.2R-04	Placing Concrete by Pumping Methods	Table 502.1
305.1—06	Specification for Hot Weather Concreting	Table 502
306.1—90	Standard Specification for Cold Weather Concreting (Reapproved 2002)	Table 502
308.1—98	Standard Specification for Curing Concrete	Table 502
318—08	Building Code Requirements for Structural Concrete and Commentary.....	Table 502
506.2—95	Specification for Shotcrete	Table 502

Standard reference number	Title	Referenced in code section number
AHRI 1160-09	Performance Rating of Heat Pump Pool Heaters.....	Table 316.2

Standard reference number	Title	Referenced in code section number
A108/A118/A136.1-2009	Specifications for Installation of Ceramic Tile.....	Table 502.1
Z21.56a-2008	Gas Fired Pool Heaters.....	Table 502.1
Z124.7-1997	Prefabricated Plastic Spa Shells	Table 502.1

Standard reference number	Title	Referenced in code section number
APSP 7-06	Standard for Suction Entrapment Avoidance in Swimming Pool, Wading Pools, Spas, Hot Tubs and Catch Basins	310.1, 311.3, 505.1.3
APSP 14-09	Portable Spa Energy Efficiency Standard	303.1
APSP 15-10	Standard for Energy Efficiency for Residential Inground Swimming Pools and Spas.....	303.1

ASCE/SEI

American Society of Civil Engineers
Structural Engineering Institute
1801 Alexander Bell Drive
Reston, VA 20191-4400

Standard reference number	Title	Referenced in code section number
ASCE 24—05	Flood Resistant Design & Construction	304.3

ASME

American Society of Mechanical Engineers
Three Park Avenue
New York, NY 10016-5990

Standard reference number	Title	Referenced in code section number
ASME A112.1.2	Air Gaps in Plumbing Systems (For Plumbing Fixtures and Water-Connected Receptors)	318.2
ASME A112.19.8	Suction Fittings for Use in Swimming Pools, Wading Pools, Spas, and Hot Tubs	202, 505.1.1
ASME B16.15-1985(R1994)	Cast Bronze Threaded Fittings.....	202, Table 311.4.1

ASTM

ASTM International
100 Barr Harbor
West Conshohocken, PA 19428-2959

Standard reference number	Title	Referenced in code section number
A240-09	Standard Specification for Chromium and Chromium-Nickel Stainless Steel Plate, Sheet and Strip for Pressure Vessels and for General Applications.....	Table 502.1
B88-03	Standard Specification for Seamless Copper Water Tube.....	Table 311.4
B447-84	Specification for Welded Copper Tube.....	Table 311.4
D1527-99(2005)	Specifications for Acrylonitrile Butadiene Styrene (ABS) Plastic Pipe, Schedules 40 and 80.....	Table 311.4, Table 311.4.1
D1593-09	Non-rigid vinyl chloride plastic sheeting.....	Table 502.1
D1785—06	Specification for Poly Vinyl Chloride (PVC) Plastic Pipe, Schedules 40, 80 and 120.....	Table 311.4
D2464-06	Standard Specification for Threaded Poly(Vinyl Chloride) (PVC) Plastic Pipe Fittings, Schedule 80.....	Table 311.4.1
D2466-06	Standard Specification for Poly(Vinyl Chloride) (PVC) Plastic Pipe Fittings, Schedule 40.....	Table 311.4.1
D2467—06	Standard Specification for Poly(Vinyl Chloride) (PVC) Plastic Pipe Fittings, Schedule 80.....	Table 313.4.1
D2846/D2846M-09b	Standard Specification for Chlorinated Poly(Vinyl Chloride) (CPVC) Plastic Hot- and Cold-Water Distribution Systems.....	Table 311.4, Table 311.4.1
F437-09	Standard Specification for Threaded Chlorinated Poly(Vinyl Chloride) (CPVC) Plastic Pipe Fittings, Schedule 80.....	Table 311.4.1
F438-09	Standard Specification for Socket-Type Chlorinated Poly(Vinyl Chloride) (CPVC) Plastic Pipe Fittings, Schedule 40.....	Table 311.4.1
F439-09	Standard Specification for Chlorinated Poly (Vinyl Chloride) (CPVC) Plastic Pipe Fittings, Schedule 80.....	Table 311.4.1
F1346-91(2003)	Standard Performance Specification for Safety Covers and Labeling Requirements for All Covers for Swimming Pools, Spas and Hot Tubs.....	305.2, 305.4
F2208-08	Standard Safety Specification for Residential Pool Alarms	305.4
G154-06	Standard Practice for Operating Fluorescent Light Apparatus for UV Exposure Of Nonmetallic Materials	804.2

CPSC

Consumer Product Safety Commission
4330 East West Highway
Bethesda, MD 30814-4408

Standard reference number	Title	Referenced in code section number
16 CFR Part 1207—04	Safety Standard for Swimming Pool Slides.....	406.8

CSA

Canadian Standards Association
5060 Spectrum Way
Mississauga, Ontario, Canada L4N 5N6

Standard reference number	Title	Referenced in code section number
CSA B137.2	Polyvinylchloride (PVC) Injection-Moulded Gasketed Fittings for Pressure Applications.....	Table 311.4.1
CSA B137.3	Rigid Polyvinylchloride (PVC) Pipe and Fitting and Pressure Applications.....	Table 311.4.1
CSA B137.6	Chlorinated Polyvinylchloride (CPVC) Pipe, Tubing, and Fitting for Hot- and Cold-Water Distribution Systems	Table 311.4.1
CSA C22. No. 108-01	Liquid Pumps.....	313.8
CSA C22. No. 218-M89(R2006)	Spas, Hot Tubs and Associated Equipment.....	302.3, 309.1, 310.1, 313.8, Table 316.2, 317.2, 509.1, 1001.4, 1001.7

FSEC

Florida Solar Energy Center
A Research Institute of the University of Central Florida
1679 Clearlake Road
Cocoa, FL 32922-5703

Standard reference number	Title	Referenced in code section number
FSEC 102-10	Test Methods & Minimum Standards for Certifying solar thermal collectors	Table 316.2
FSEC 202-10	Test Method for Photovoltaic Module Power Rating Table	Table 316.2

IAPMO

International Association of Plumbing and Mechanical Officials
4755 East Philadelphia
Ontario, CA 91761

Standard reference number	Title	Referenced in code section number
IS-2-90	Tile Lined Roman Bathtubs	Table 502.1
PS-33-93	Specification for Flexible Hose for Pools, Hot tubs, Spas and Jetted Bathtubs.....	Table 311.4

ICC

International Code Council, Inc.
500 New Jersey Avenue, NW
6th Floor
Washington, DC 20001

Standard reference number	Title	Referenced in code section number
IBC-12	International Building Code®	201.3, 304.2, 306.1, 306.3, 307.2, 307.4, 307.8, 307.9, 410.1, 609.1
IECC-12	International Energy Conservation Code®	201.3, 316.4
IFC-12	International Fire Code®	201.3
IFGC-12	International Fuel Gas Code®	201.2, 316.4
IMC-12	International Mechanical Code®	201.3, 316.4
IPC-12	International Plumbing Code®	201.3, 302.2, 302.5, 302.6, 306.8, 306.8.1, 318.2, 410.1, 609.1
IRC-12	International Residential Code®	102.7.1, 201.3, 302.1, 302.5, 302.6, 306.1, 306.3, 306.8, 306.8.1, 307.2, 307.4, 307.8, 316.4, 318.2, 321.2.1, 703.1, 802.1, 802.2

NEMA

National Electrical Manufacturers Association
1300 North 17th Street
Suite 1752
Rosslyn, VA 2209

Standard reference number	Title	Referenced in code section number
NEMA Z535-2006	ANSI/NEMA Color Chart.....	409.3

NFPA

National Fire Protection Association
1 Batterymarch Park
Quincy, MA 02269

Standard reference number	Title	Referenced in code section number
NFPA 70-2011	National Electric Code.....	302.1, 316.4, 321.2.1

NSF

NSF International
789 Dixboro Road
Ann Arbor, MI 48105

Standard reference number	Title	Referenced in code section number
NSF 14-2010	Plastics Pumping Systems components and Related Materials.....	302.3, 311.4
NSF 50-2009	Equipment for Swimming Pools, Spas, Hot Tubs, and other Recreational Water Facilities.....	302.3, 304.1, 309.1, Table 316.2, 508.1

UL

Underwriters Laboratories Inc.
333 Pfingsten Road
Northbrook, IL 60062

Standard reference number	Title	Referenced in code section number
UL 372-2007	Automatic Electrical Controls for Household and Similar Use - Part 2: Particular Requirements for Burner Ignition Systems and Components.....	506.2.1, 506.22
UL 873-2007	Temperature-Indicating and -Regulating Equipment.....	506.2.6
UL 1004-1—08	Standard for Rotating Electrical Machines General Requirements.....	313.8
UL 1004-2—08	Standard for Impedance Protected Motors.....	313.8
UL 1004-3—08	Standard for Thermally Protected Motors.....	313.8
UL 1004-4—08	Standard for Electric Generators.....	313.8
UL 1004-5—08	Standard for Fire Pump Motors.....	313.8
UL 1004-6—09	Standard for Servo and Stepper Motors.....	313.8
UL 1004-7—09	Standard for Electronically Protected Motors.....	313.8
UL 1004-8—09	Standard for Inverter Duty Motors.....	313.8
UL 1081-2008	Standard for Swimming Pool Pumps, Filters and Chlorinators.....	313.8
UL 1261-2001	Standard for Electric Water Heaters for Pools and Tubs.....	Table 316.2
UL 1563-2009	Standard for Electric Hot Tubs, Spas and Associated Equipment.....	302.3, 309.1, 310.1, 313.8Table 316.2, 317.2, 509.1, 1001.4, 1001.7
UL 1995-2005	Heating and Cooling Equipment.....	Table 316.2